

FEFCO

International fibreboard
case code

Code international pour
emballage carton

Internationaler code für
versandverpackungen

Codice internazionale per
imballaggi in cartone ondulato

Código internacional para
cajas de cartón ondulado

FEFCO
Corrugated Packaging

**International fibreboard
case code**

**Internationaler code für
versandverpackungen**

**Code international pour
emballage carton**

**Codice internazionale per
imballaggi in cartone ondulato**

**Código internacional para
cajas de cartón ondulado**

PUBLISHED BY FEFCO

Avenue Louise 250
Belgium
www.fefco.org

ESBO

Laan Copes van Cattenburch 79
P.O. BOX 85612
NL-2508 CH The Hague
Netherlands
www.esbo.nl

*Adopted by **ICCA**, the International
Corrugated Case Association, with its
worldwide membership.*

*Von **ICCA**, dem Internationalen
Verband der Wellkistenhersteller,
weltweit anerkannt.*

*Adopté par **ICCA**, l'Association
Internationale des Fabricants de
Carton Ondulé, sur le plan mondial.*

*Adottato da **ICCA**, l'Associazione
Internazionale dei produttori di
cartone ondulato, con la sua
appartenenza a livello mondiale.*

















*Adoptado por **ICCA**, la Asociación
Internacional de Cajas de Cartón
Ondulado, con sus asociados a nivel
mundial.*

Internationaler code für versandverpackung

Der vorliegende Code wurde von der FEFCO und der ESBO ausgearbeitet mit dem Ziel, umständliche Definitionen von Wellpappeschachtel- und Verpackungskonstruktionen durch einfache, international gültige Symbole zu ersetzen, die unabhängig von sprachlichen und anderen Schwierigkeiten allgemein verständlich sind.

Der Code kann ferner für Aufträge und Spezifikationen von Versandverpackungen benutzt werden. Änderungen und Ergänzungen können nur die FEFCO bzw. die ESBO vornehmen.

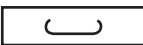
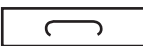
Für Zeichnungen und Rechnersysteme verwendete Symbole

Symbol	Beschreibung	Rechnercode
Schneid- und Rilllinien, Schlitz, Ausstanzungen usw.		
	CL	Konturen fertig geformter Schachteln bzw. Schneidlinien von Schachtelzuschnitten
	SC	Ausgestanzte Schlitz
	CI	Rilllinien der Zuschnitte (nach innen faltend)
	CO	Rilllinien der Zuschnitte (nach außen faltend)
	SI	Ritzlinien der Zuschnitte (nach innen faltend)
	SO	Ritzlinien der Zuschnitte (nach außen faltend)
	DS	Doppelte Rilllinien der Zuschnitte
	PL	Perforationslinien der Zuschnitte
	SE	Weiche Schnittkanten der Zuschnitte (nur Wellpappe)
	TP	Aufreißperforation
Fabrikanten- und Laschenverbindungen		
	SJ	Verbindung durch Drahtheftung
	TJ	Verbindung durch Klebestreifen
	GJ	Verbindung durch Laschenklebung
Handgriff-Öffnungen		
	PC	Handgrifföffnung, ausgebrochen
	UC	Handgrifföffnung, nicht ausgebrochen
	NC	Handgrifföffnung, nicht ausgebrochen
Wellenrichtung		
	FD	Wellenrichtungsanzeiger

Die Skizzen der in diesem Leitfaden aufgeführten Schachteltypen sind vom Innern der Schachtel her gesehen dargestellt.

Abmessungen der Schachteln

Sofern nichts anderes angegeben ist, werden als Abmessungen die im folgenden definierten Innenmaße in mm angeführt:

Länge (L) x Breite (B) x Höhe (H)

Länge (L) = die längere Abmessung an der Öffnungsseite

Breite (B) = die kürzere Abmessung an der Öffnungsseite

Höhe (H) = die Abmessung zwischen der Oberkante an der Öffnungsseite und der Bodenkante

Die Größen L, B, H, sind in jeder Beschreibung der Gehäusekonstruktion angegeben. Bei einigen Modellen kann der numerische Wert von B dem numerischen Wert von L übersteigen.

Die Maße sind unter genormten klimatischen Bedingungen am flachliegenden Zuschnitt von der Rilllinienmitte aus unter Berücksichtigung der Packstoffdicke zu messen. Bei Deckel- oder Stülpschachteln ist die Höhe (h) des oberen Teils (Deckels) als viertes Maß hinter einem Schrägstrich anzugeben:

355 x 205 x 120/40 mm

(L) (B) (H) (h)

Bei Schachteln mit überlappenden äußeren Verschlussklappen ist die Länge bzw. die Fläche der Überlappung (O) als viertes Maß anzugeben:

355 x 205 x 120/40 mm

(L) (B) (H) (O)

Abmessungen der Wellpappebögen

Die Abmessungen eines Wellpappebogens sind, wenn nichts anderes vermerkt ist, wie folgt in mm angegeben:

Abmessung 1 x Abmessung 2

Abmessung 1 = entlang der Klebelinien

Abmessung 2 = quer zu den Klebelinien

Abgewandelte Ausführungen

Bei bestimmten Schachteltypen kann es sich um Abwandlungen von Standardausführungen handeln, wobei es nicht notwendig ist, eine neue Typenbezeichnung zu kreieren. In diesem Fall ist die Nummer des Grundtyps durch eine Zahl zu ergänzen, die von ersterer durch einen Bindestrich abgetrennt wird: 0201-2. Bei bestimmten Ausführungen kann es sich um einmalige Konstruktionen einzelner Hersteller handeln

Kombinationen von Schachteltypen

In dem Katalog sind die Grundtypen von Vollpappe- und Wellpappeschachteln abgebildet. Ist eine Ausführung eine Kombination aus Elementen mehrerer Grundformen,

beispielsweise von verschiedenen Klappen, kann die Beschreibung wie folgt lauten: Deckelklappen wie 0204, Bodenklappen wie 0215 oder auch 0204/0215 (Deckelklappen/Bodenklappen).

0204 0215 0204/0215

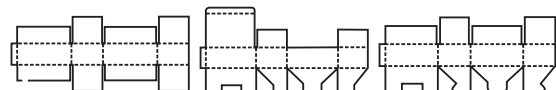

Verschiedene Ausführungen und die Fabrikante

Die in dem Katalog enthaltenen Zeichnungen der verschiedenen Ausführungen müssen u.U. entsprechend der jeweiligen Fabrikante neu gestaltet werden. Die Fabrikanten werden durch Laschenklebung, Drahtheftung bzw. durch Klebestreifen verbunden. In den beiden ersten Fällen können die Laschen als Verlängerungen einer kurzen bzw. einer langen Seitenwand gestaltet werden. Aus den Skizzen geht hervor, wie diese in Zeichnungen dargestellt werden.

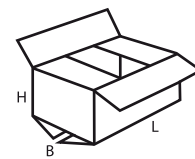

0201

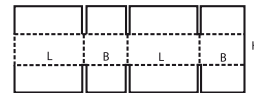

Verbindung durch Klebestreifen

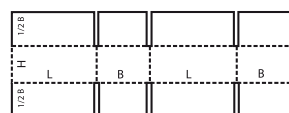

Verbindung durch Laschenklebung bzw. Drahtheftung

Das trifft auf alle in diesem Katalog aufgeführten Ausführungen zu.

Manuelles oder automatisches Aufrichten

Zu jeder Bauart gehört eine der folgenden Bezeichnungen
M - üblicherweise manuelles Aufrichten
A - üblicherweise automatisches Aufrichten
M/A = manuell oder automatisch
M+A = eine Kombination beider Aufrichtungsarten ist erforderlich.

Diese Hinweise basieren auf den aktuellen Erfahrungen und sollen als zusätzliche Information für Verpackungsentwickler und -benutzer dienen. Einige Schachteln, die für manuelle Aufrichtung vorgesehen sind, können automatisch geschlossen werden (z.B. die Nummern 0216 oder 0712).

Beschreibung der Schachteln-Grundtypen*

Schreibung des Typencodes

*Die Begriffe «Schachteln» und «Kisten» sind in dieser Beschreibung austauschbar.

Hinweis

Bitte beachten Sie, daß manche der im Katalog unter einer bestimmten Nummer aufgeführten Kistenausführungen u.U. auch unter anderen Grundtypen erscheinen können.

01 - Handelsübliche Rollen und Bögen

02 - Faltschachteln (Faltkisten)

Faltschachteln (Faltkisten) bestehen in der Regel aus einem Zuschnitt mit einer durch Laschenklebung, Drahtheftung bzw. Klebestreifen verbundenen Fabrikante sowie Deckel- und Bodenklappen. Sie werden flach zusammengeklappt versandt, sind gebrauchsfertig und werden mit der Hilfe von Klappen verschlossen.

03 - Deckelschachteln

Deckelschachteln (Stülp-schachteln) bestehen aus zwei oder mehr Teilen. Ein Oberteil (Deckel) wird über ein Unterteil (Boden) gestülpt oder beide über einen Rumpf.

04 - Falthüllen und Trays

Falhhüllen und Trays bestehen im allgemeinen aus einem Zuschnitt. Zwei oder alle Seitenwände und der Deckel sind am Boden angelenkt. Sperrvorrichtungen, Handgriffe, Displays usw. können bei dieser Ausführungsart integriert werden.

05 - Schiebeschachteln

Schiebeschachteln (Gürtelschachteln) bestehen aus mehreren in verschiedenen Richtungen ineinanderschließbaren Ringeinsätzen und Manschetten. Zu dieser Gruppe gehören auch Hülsen für andere Schachteltypen.

06 - Formfeste Schachteln

Formfeste Schachteln bestehen in der Regel aus zwei Seitenteilen und einem Mittelteil, das Boden und Deckel bildet. Diese Schachteln können als vorbereitete Zuschnitte geliefert werden und werden dann vom Verbraucher durch Drahtheftung oder mit alternativen Methoden untereinander verbunden.

07 - Fertig geklebte Schachteln

Fertig geklebte Schachteln sind einteilige, faltbare Schachteln, die zusammengelegt geliefert und durch einfaches Aufrichten gebrauchsfertig aufgestellt werden. Die Schachteln können mit einem Faltboden (Faltbodenschachtel) oder mit Diagonalbiegung (Aufrichteschachtel) ausgerüstet sein.

09 - Inneneinrichtungen

Inneneinrichtungen wie Einlagen, Einsätze, Stege, Trennwände, Gefache, Polster und dgl., mit der Kiste fest verbunden oder als getrennte Elemente. Zahlenangaben für Wände sind beliebig und können sich ändern.

Aufbau des Typencodes

Vollständiger Code: XXXX-XXXX	
Typ	Abwandlung
XXXX	-XXXX
Die Standardform bzw. -ausführung nach diesem Katalog	Die Nummer zur Unterscheidung der von der Standardausführung abweichenden Form (einem individuellen Modell entsprechend oder einem, das in einer CAD/ CAM-Programm-bibliothek enthalten ist).

Verschließen der Schachteln

Der sachgemäße, sichere Verschluss der Schachteln ist ebenso wichtig wie die Konstruktion der Verpackung. Der Verschluss erfolgt nach den folgenden Verfahren, die einzeln oder miteinander kombiniert angewandt werden:

- Laschenklebung (kalt oder heiß)
- Klebestreifenklebung
- Verriegelung
- Drahtheftung

Verschluss durch Klebestreifen

Der Verschluss durch Klebestreifen kann gemäß den gezeigten Beispielen erfolgen.

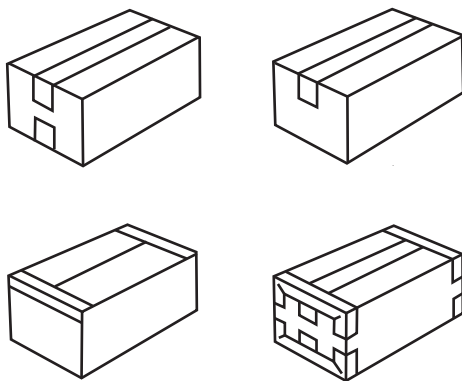

Verschluss durch Drahtheftung

Der Verschluss durch Drahtheftung kann gemäß den gezeigten Beispielen erfolgen.



Kodifizierung der Inneneinrichtungen

Die folgenden Inneneinrichtungen werden nach der Anzahl der verwendeten Tafeln codiert, und zwar in jeder Kombination (für Computersysteme).

Anzahl der Tafeln		CODE
2	>	0982
3	>	0983
4	>	0984
5	>	0985
6	>	0986
7	>	0987
8	>	0988
9	>	0989
10	>	0990
11	>	0991
12	>	0992
13	>	0993
14	>	0994
15	>	0995
16	>	0996
17	>	0997
18	>	0998
19	>	0999

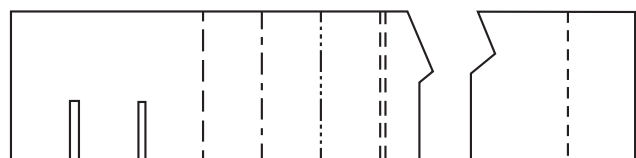

0982/0999

M

0100

- ▲ **Commercial rolls and sheets**
- ▲ **Bobines, feuilles ou plaques commerciales.**
- ▲ **Handelsübliche Rollen und Tafeln**
- ▲ **Bobine e fogli pronti per vendita**
- ▲ **Rollos y planchas comerciales**

0100

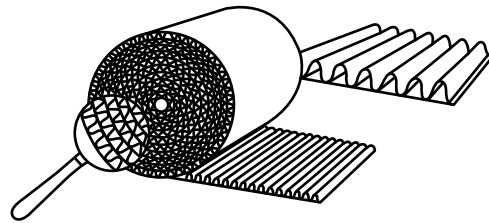

0110

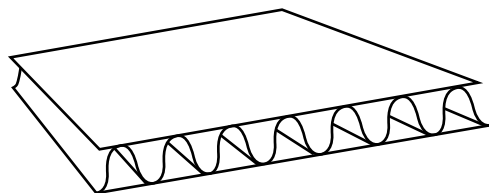

0200

- ▲ **Slotted-type boxes** consist of basically one piece with a glued, stitched or taped manufacturers joint and top and bottom flaps. They are shipped flat, ready to use and require closing using the flaps provided.
- ▲ **Caisses à rabats**, d'une seule pièce, avec joint d'assemblage collé, agrafé ou à bande gommée. Elles sont livrées à plat, prêtes à l'emploi et nécessitent d'être fermées.
- ▲ **Faltschachteln (Faltkisten)** bestehen in der Regel aus einem Stück mit einer durch Laschenklebung, Drahtheftung bzw. Klebestreifen verbundenen Fabrikante sowie Deckel- und Bodenklappen. Sie werden flach zusammengefasst versandt, sind

gebrauchsfertig und werden anhand der Klappen verschlossen.

- ▲ **Case a falde**: Scatole americane costruite in un singolo pezzo base con la giunta incollata, cucita o nastrata e con falde superiori e inferiori. Sono consegnate stese, pronte da utilizzare e richiedono chiusura tramite le apposite falde.
- ▲ **Cajas de tipo ranurado**: consisten básicamente en una pieza con juntas de fabricación encolada, cosida o pegada con cinta y solapas superiores e inferiores. Se despachan extendidas en un plano, listas para su uso y se cierran utilizando las solapas superiores e inferiores.

0200 M/A

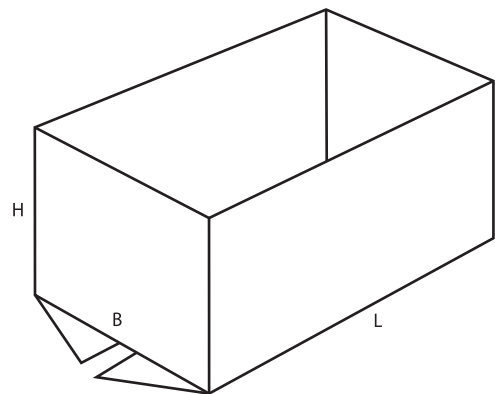
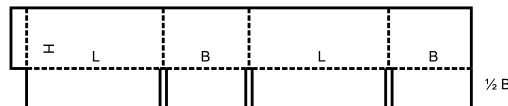

0201 M/A

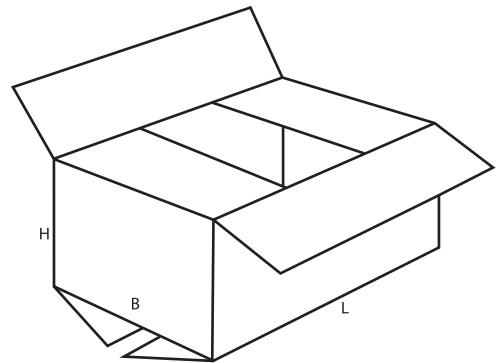
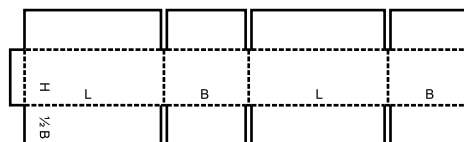

0202 M/A

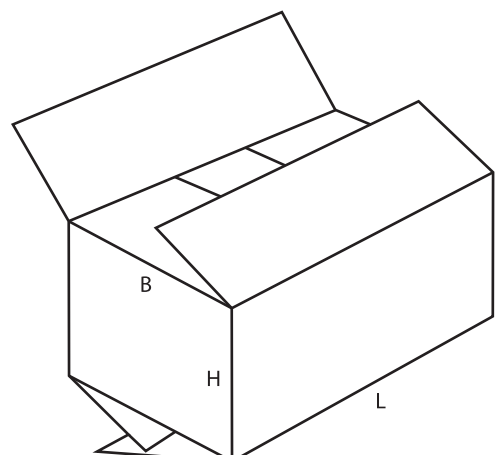
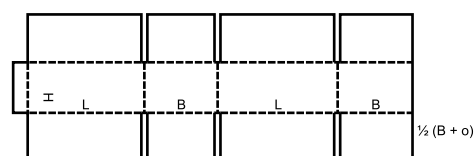

0203 M/A

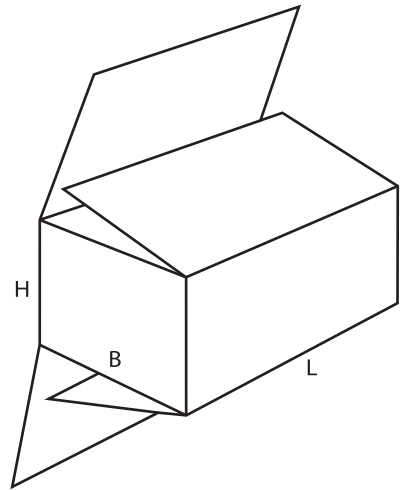
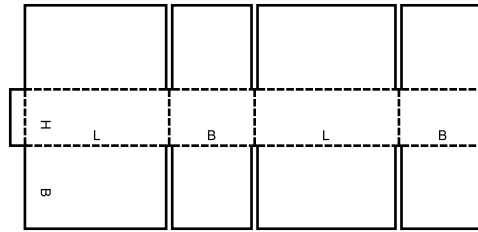

0204 M/A

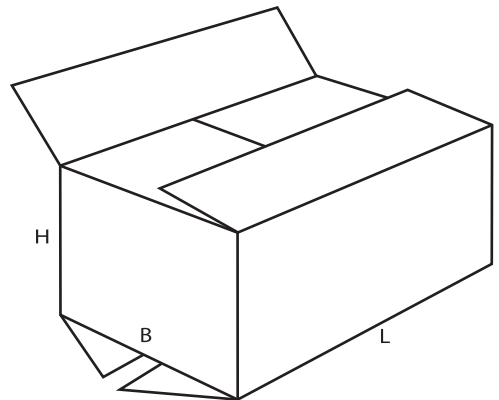
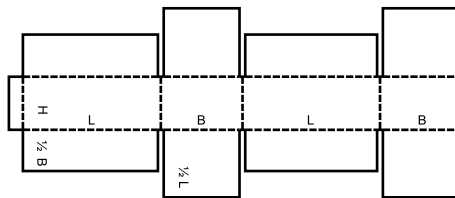

0205 M/A

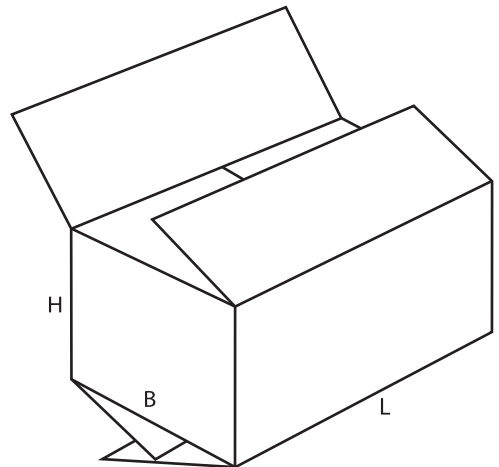
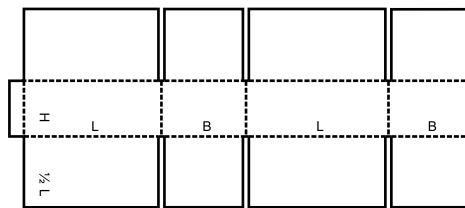

0206 M/A

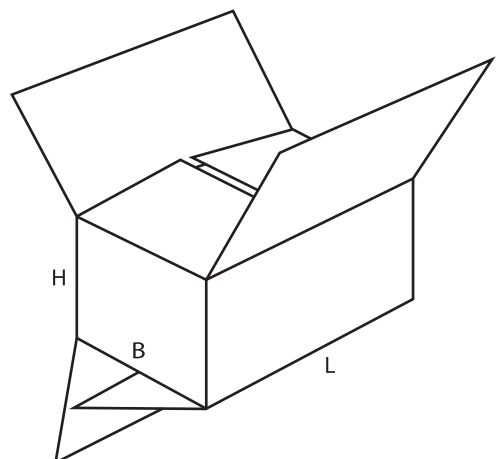
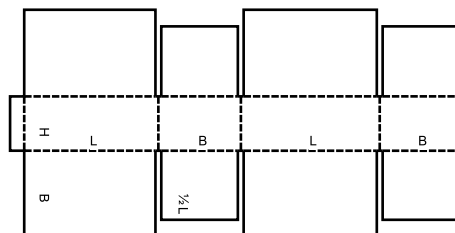

0207 M

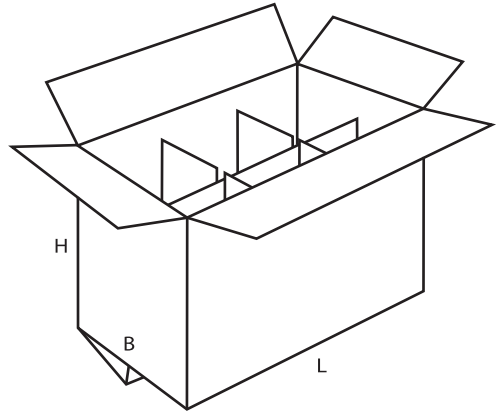
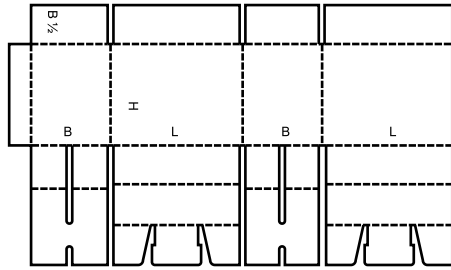

0208 M

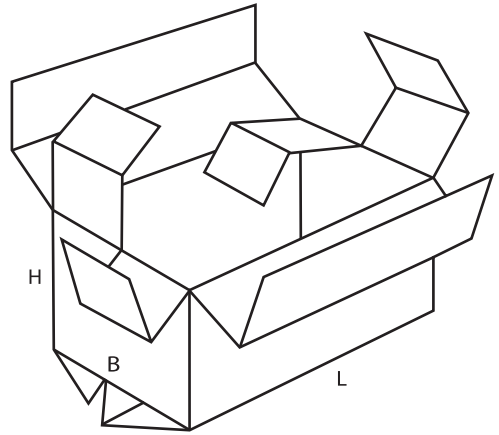
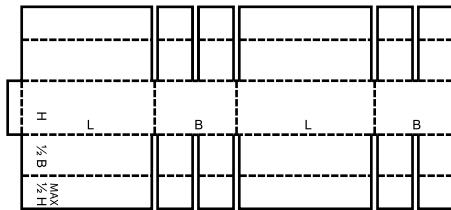

0209 M/A

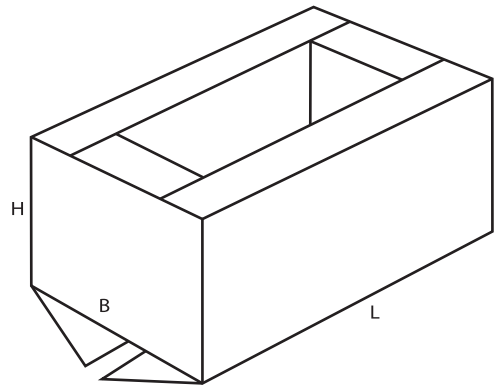
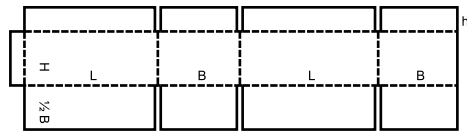

0210 M

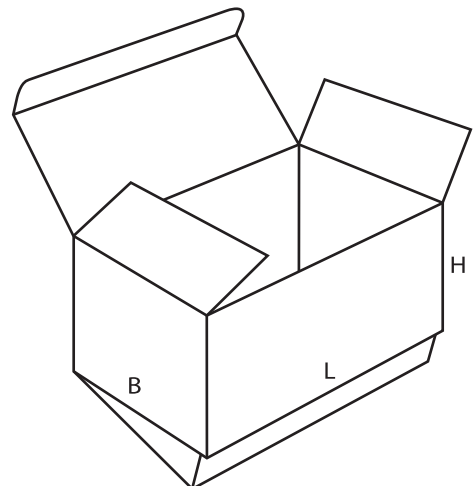
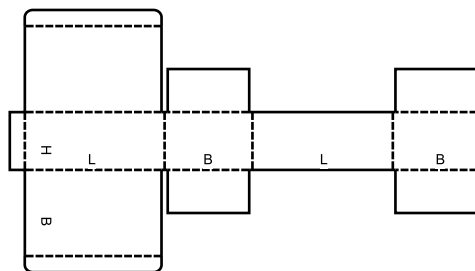

0211 M

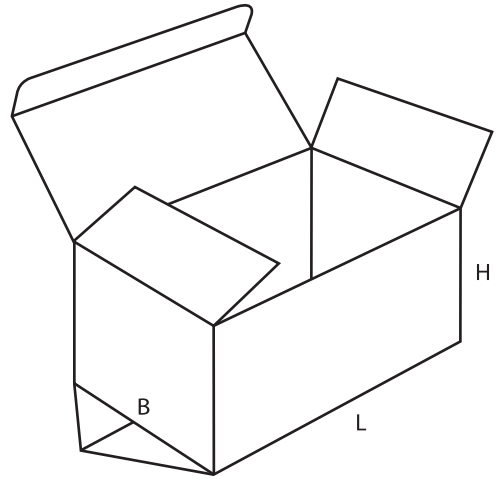
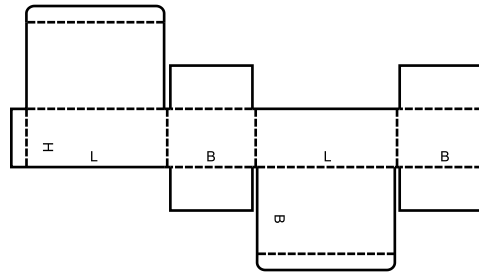

0212 M/A

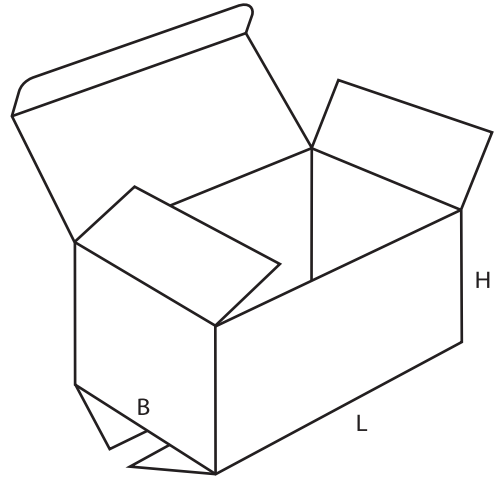
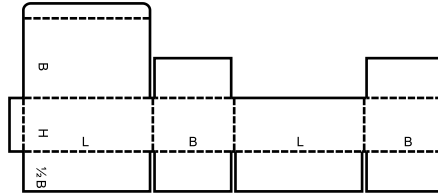

0214 M

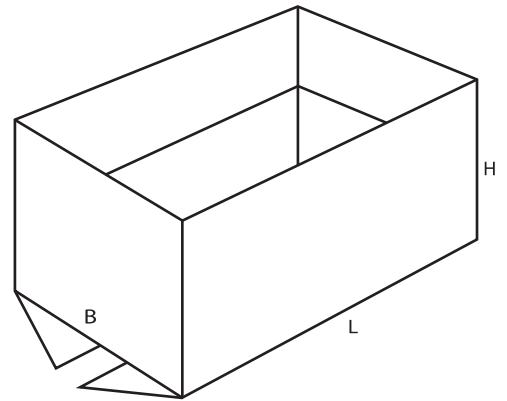
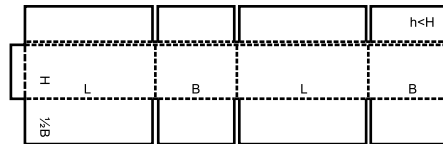

0215 M

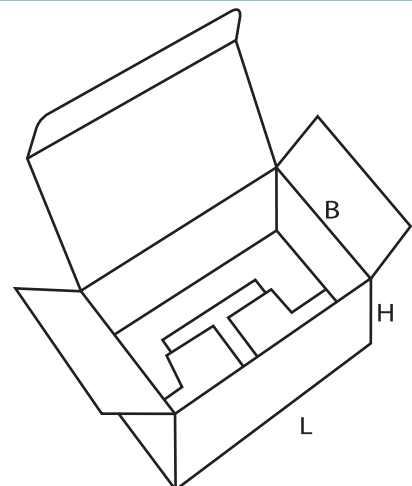
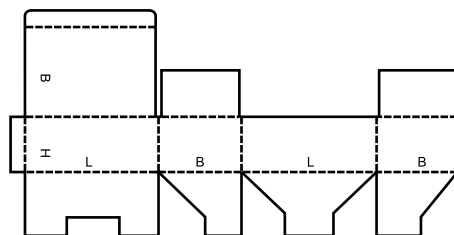

0216 M

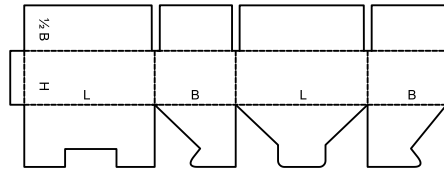

closure of top can be automated
 la fermeture du dessus peut être automatisée
 Der Verschluss des Aufsatzes kann automatisiert werden

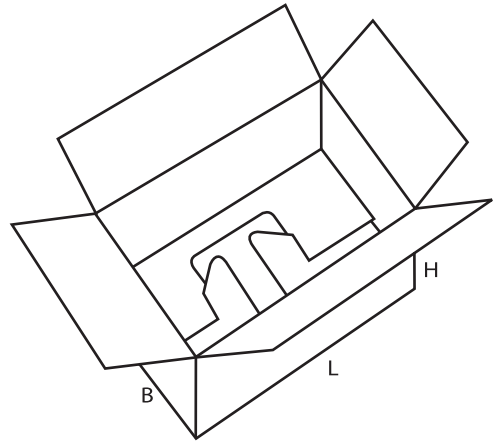

0217 M

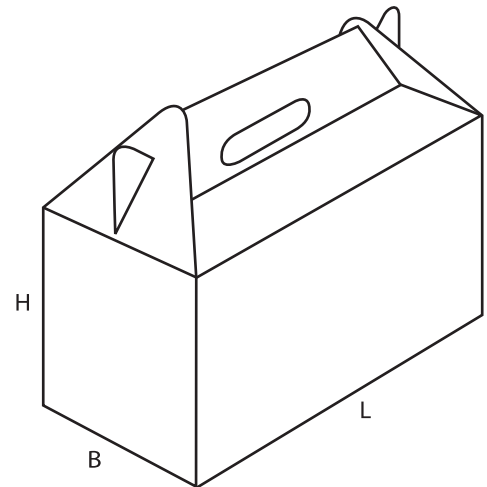
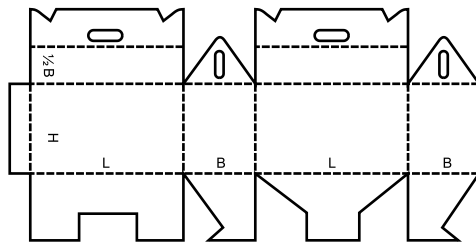

0218 M

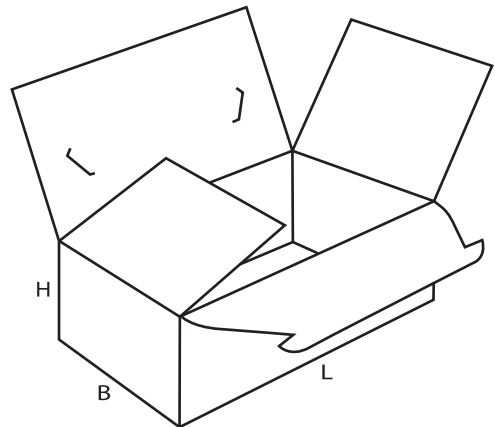
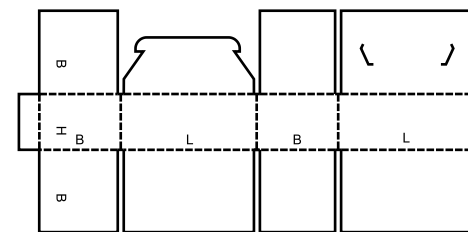

0225 M

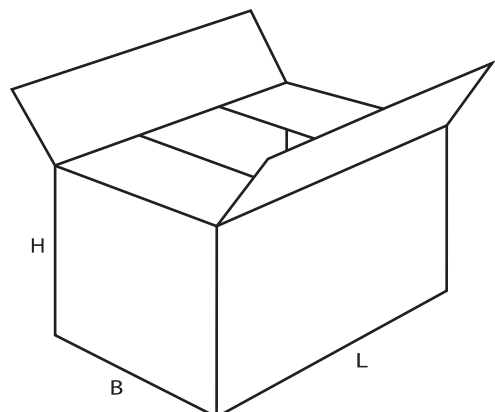
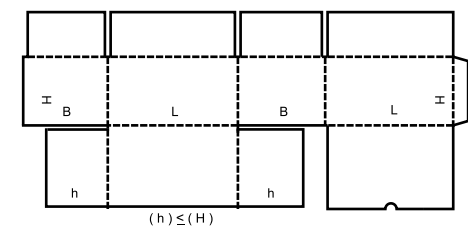

0226 M

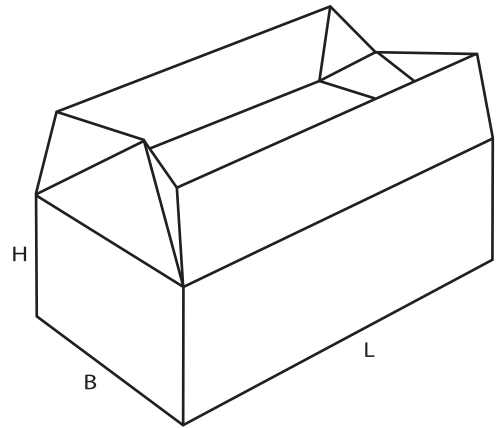
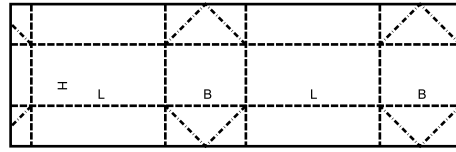

0227 M

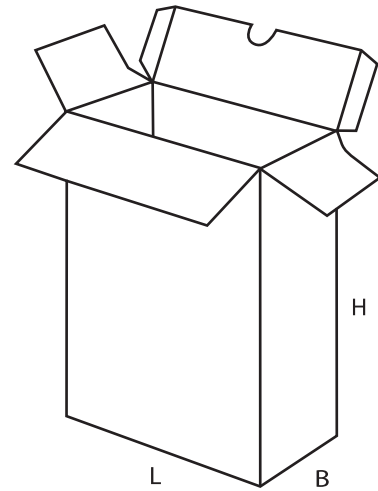
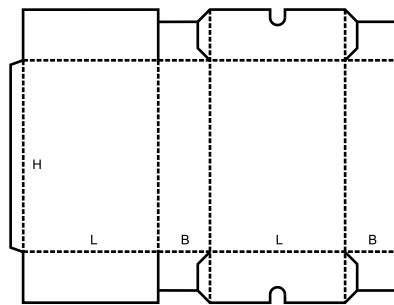

0228 M/A

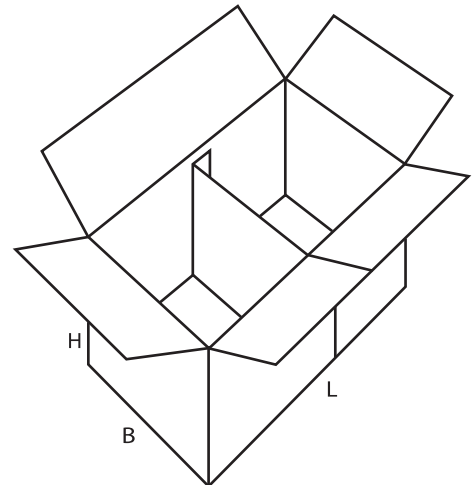
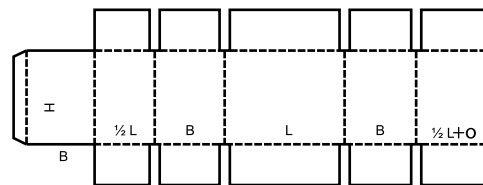

0229 M

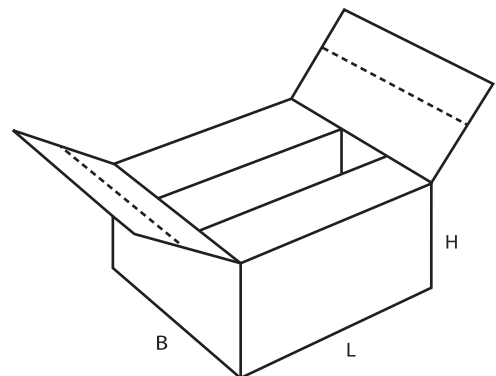
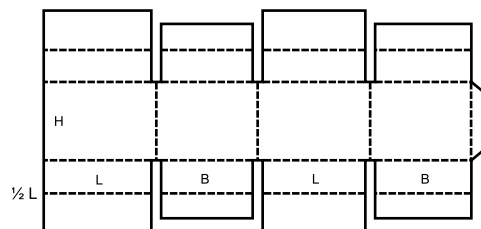

0230 M/A

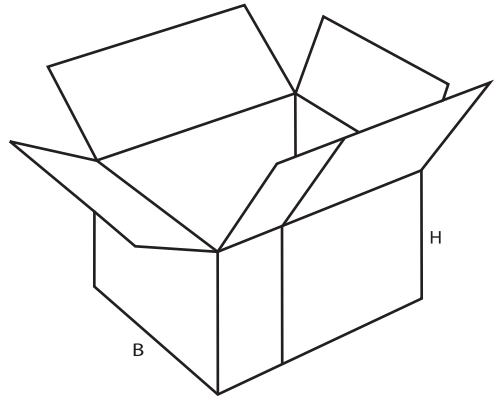
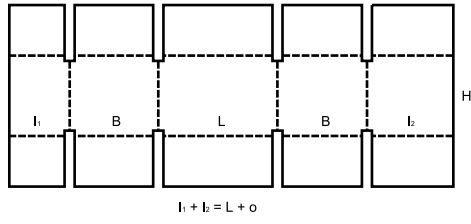

0231 M/A

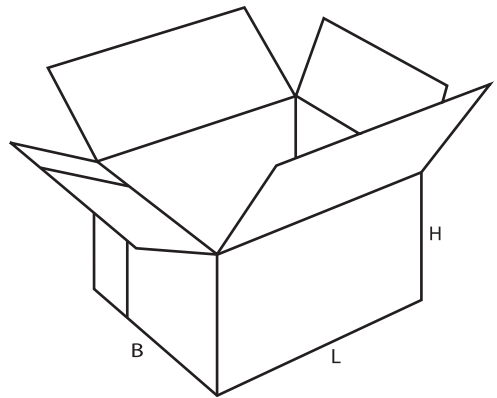
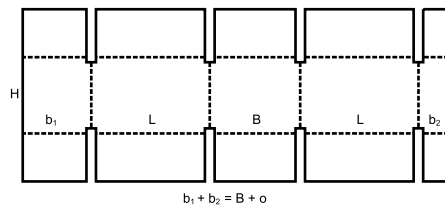

0300

- ▲ **Telescope-type** boxes consist of more than one piece and are characterised by a lid and/or bottom telescoping over the body of the box.
- ▲ **Caisses télescopiques** constituées par plus d'une pièce et caractérisées par un couvercle et/ou un fond séparé se glissant sur le corps de la caisse.
- ▲ **Deckelschachteln (Stülp-schachteln)** bestehen aus zwei oder mehr Teilen. Ein Oberteil (Deckel) wird über ein Unterteil (Boden) gestülpt oder beide über einen Rumpf.

- ▲ **Casse telescopiche:** Scatole telescopiche costituite da più di un componente e caratterizzate da un coperchio e/o fondo che scorre esternamente al corpo della scatola.
- ▲ **Cajas telescópicas:** fabricada con más de una pieza, se caracterizan por una tapa y/o fondo que se desliza sobre el cuerpo de la caja.

0300 M/A

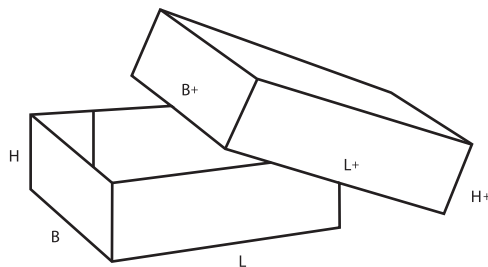
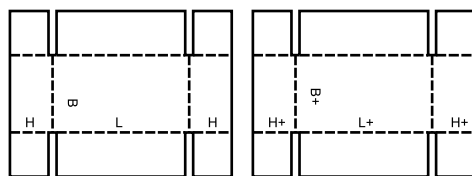

0301 M/A

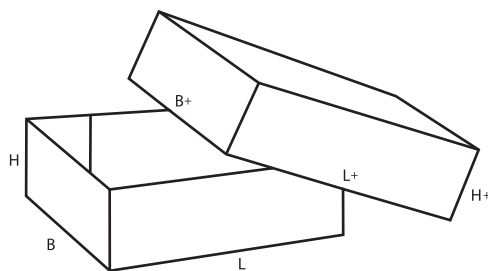
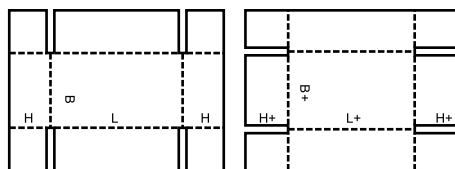

0302 M

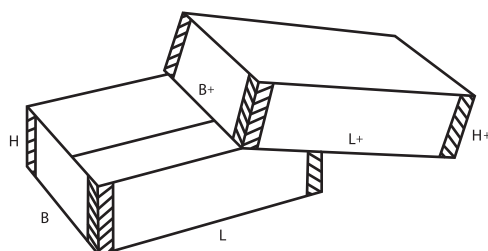
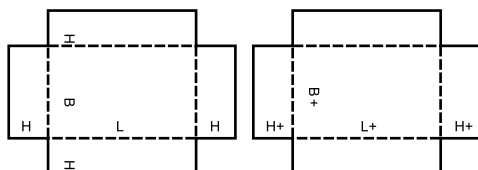

0303 M

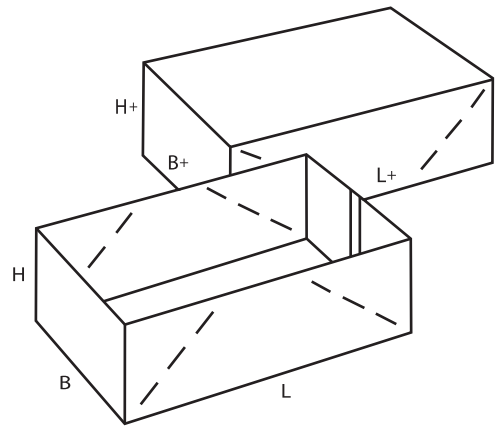
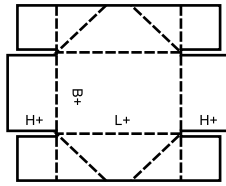
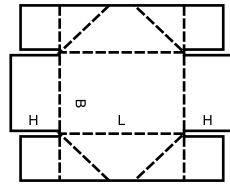

0304 M

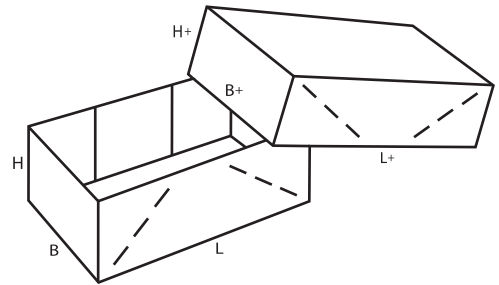
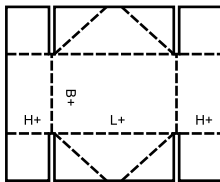
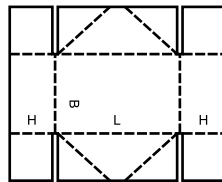

0306 M/A

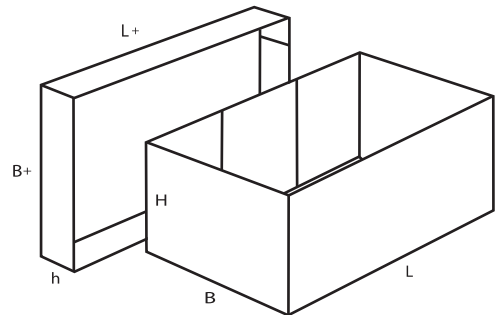
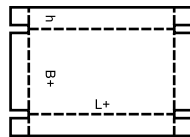
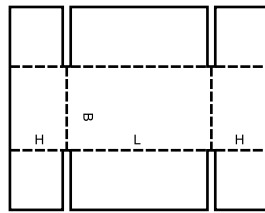

0307 M

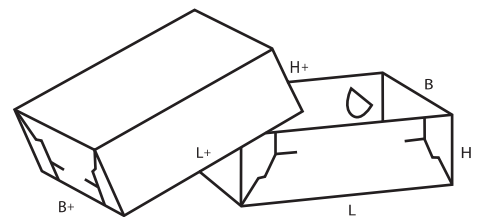
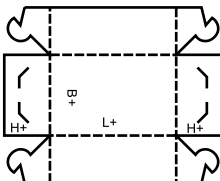
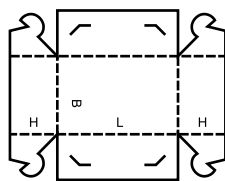

0308 M

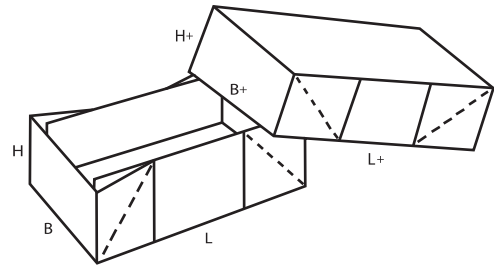
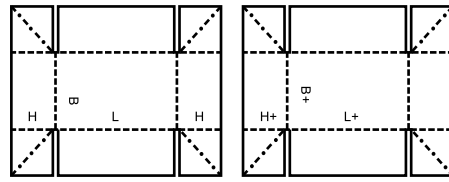

0309 M

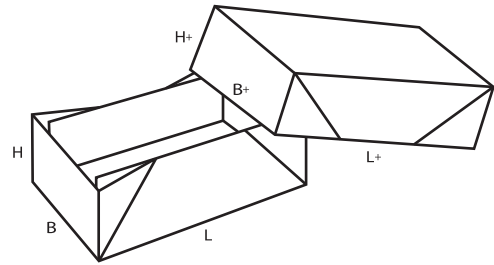
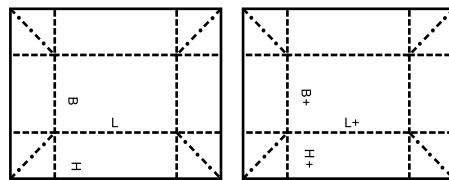

0310 M+A

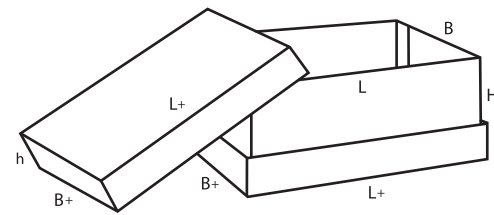
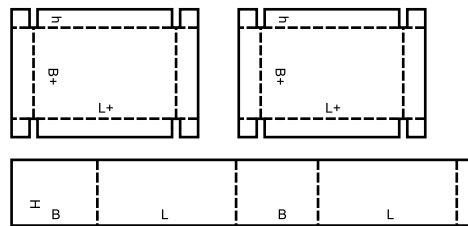

0312 M/A

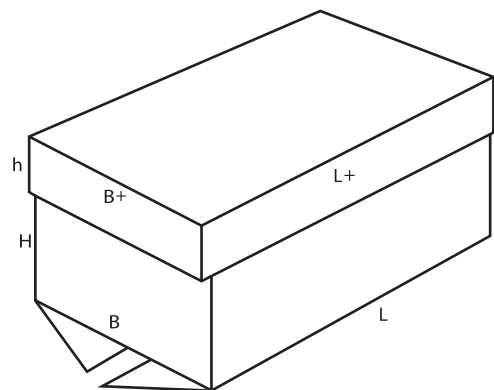
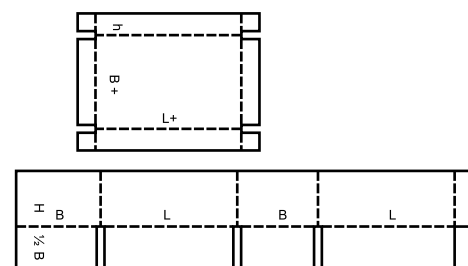

0313 M/A

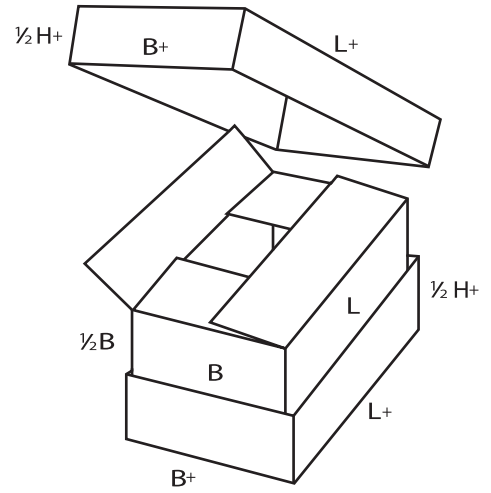
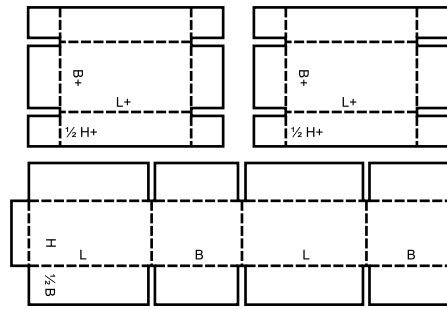

0314 M

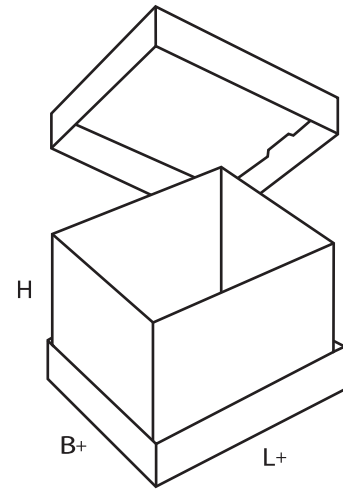
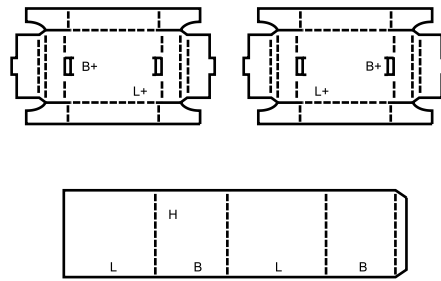

0320 M/A

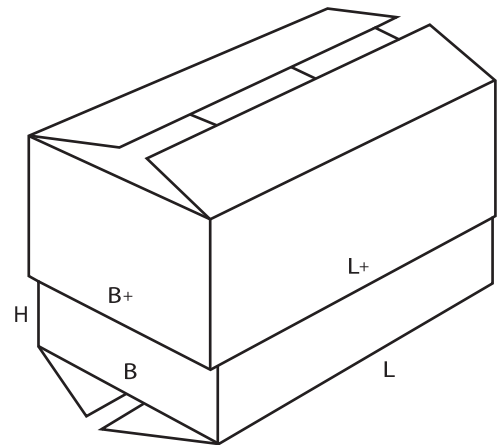
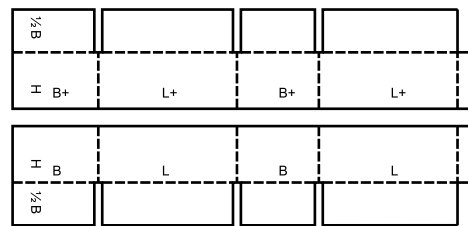

0321 M

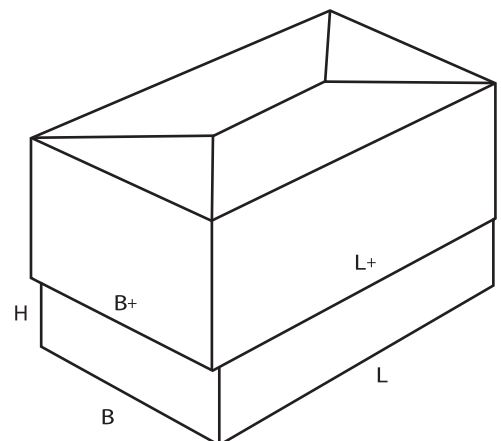
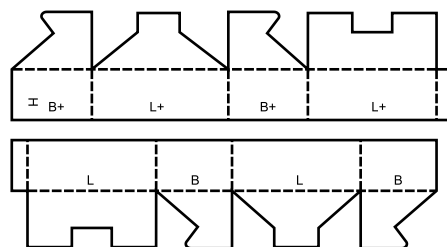

0322 M

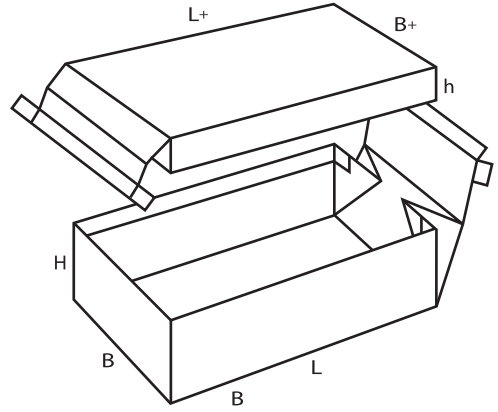
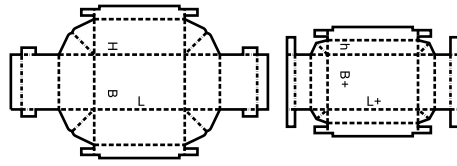

0323 M

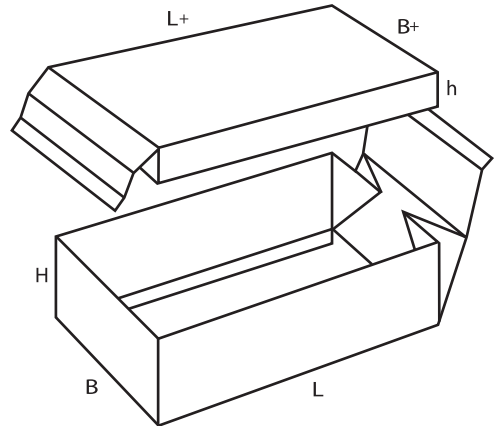
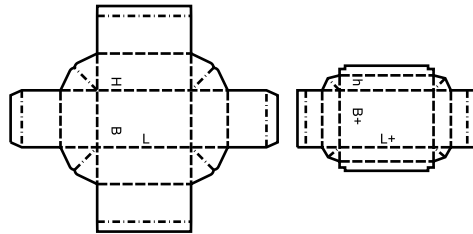

0325 A

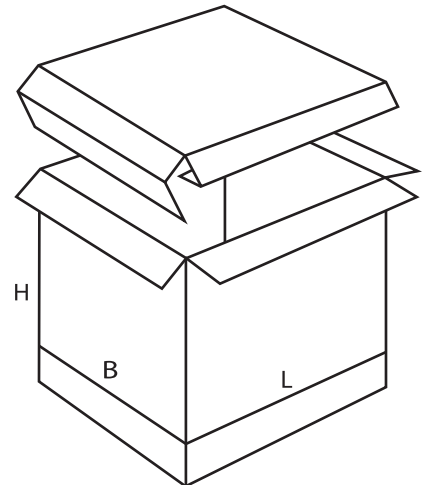
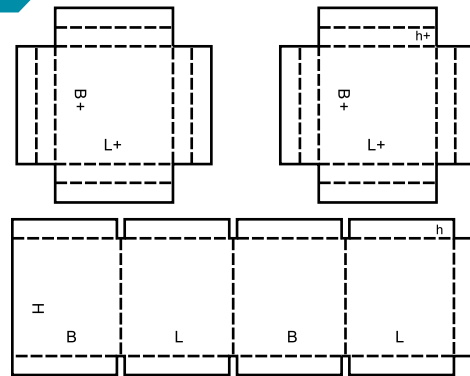

0330 M/A

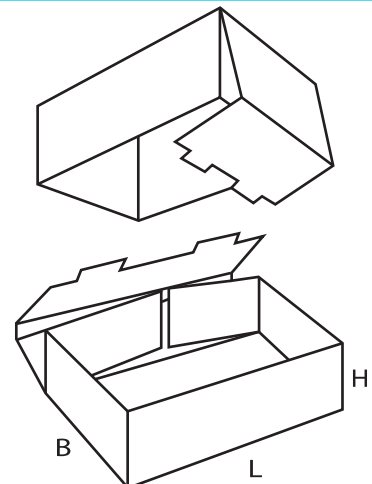
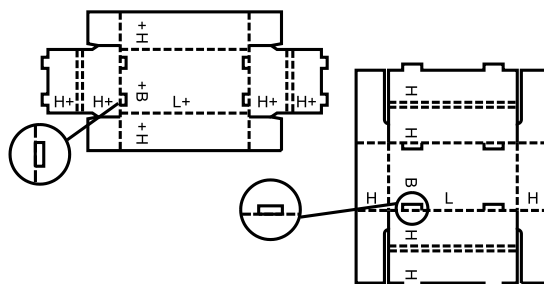

0331 M/A

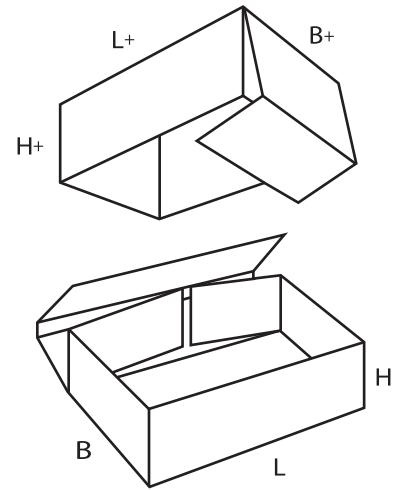
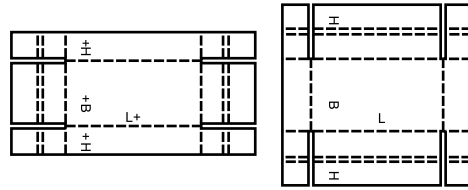

0350 M

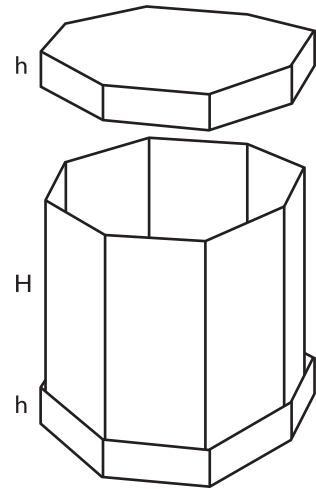
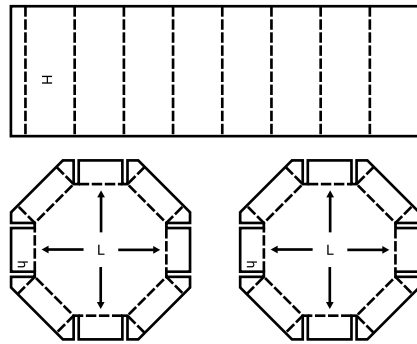

0351 M/A

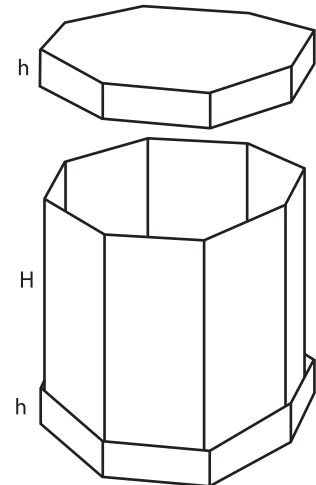
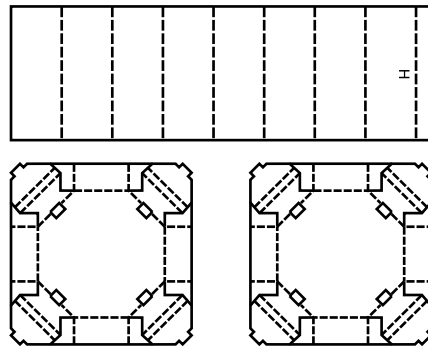

0352 M/A

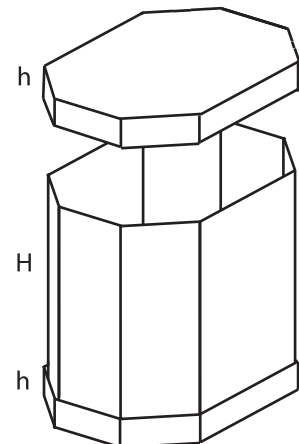
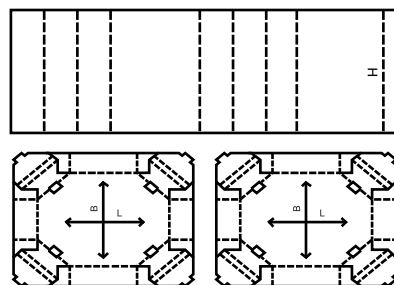

0400

- Folder-type boxes** and trays usually consist of only one piece of board. The bottom of the box is hinged to form two or all side walls and the cover. Locking tabs, handles, display panels etc., can be incorporated in some designs.
- Enveloppes et plateaux** en général constitués d'une seule pièce, montés sans agrafage ni bande gommée, et pouvant comporter des éléments de verrouillage, d'encliquetage, et des poignées.
- Falzhüllen und Trays** bestehen im allgemeinen aus einem Zuschnitt. Zwei oder alle Seitenwände und der Deckel sind am Boden angelenkt. Sperrvorrichtungen, Handgriffe, Verkaufsteller usw. können bei dieser

Ausführungsart mit vorgesehen werden.

- Scatole pieghevoli e vassoi:** Contenitori e vassoi formati normalmente dalla piegatura di un pezzo di cartone. Il fondo del contenitore è delimitato da pieghe in modo da formare due o tutti i pannelli laterali ed il pannello superiore. In certi modelli possono essere incorporati delle linguette di chiusura, delle maniglie, dei pannelli da espositori ecc.
- Cajas plegables y bandejas:** son en general de una única pieza de cartón ondulado. El fondo de la caja se pliega para formar dos, o todas las paredes laterales, y la tapa. Pueden incorporarse al diseño elementos de cierre, asas, paneles expositores, etc.

0400 M

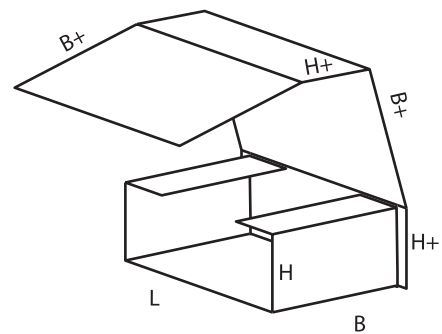
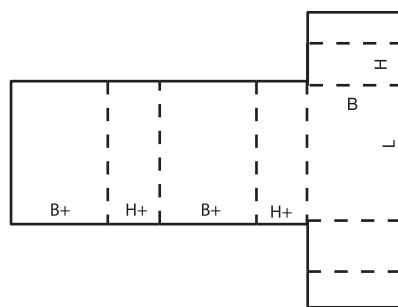

0401 M

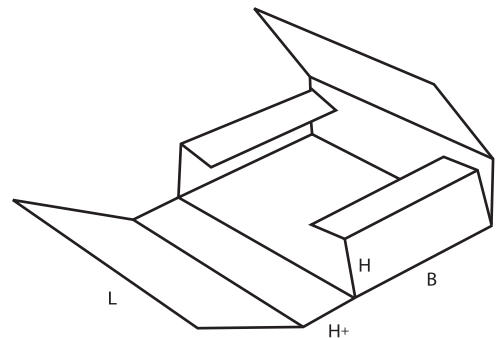
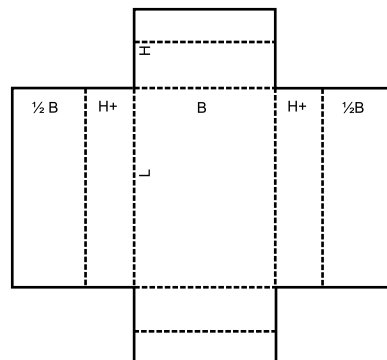

0402 M

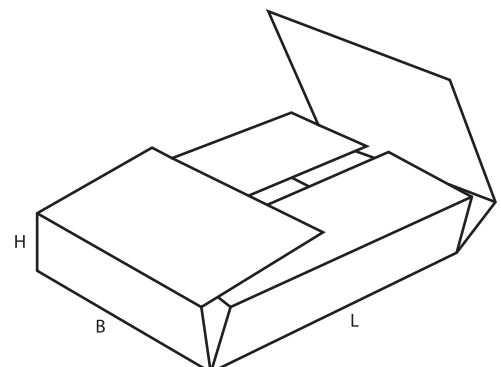
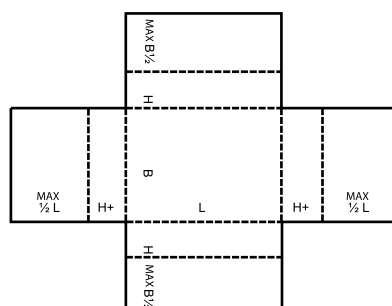

0403 M

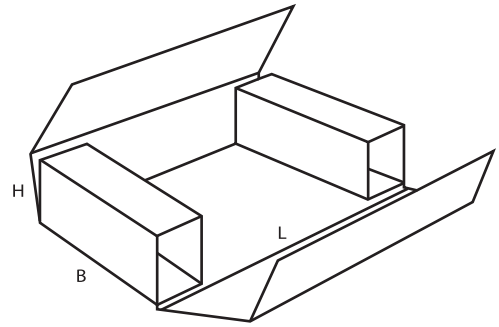
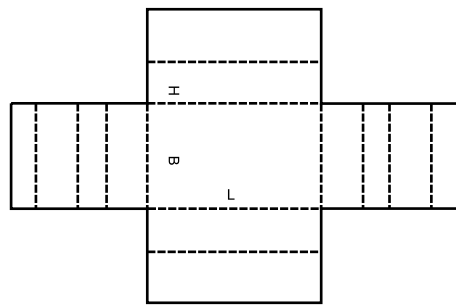

0404 M

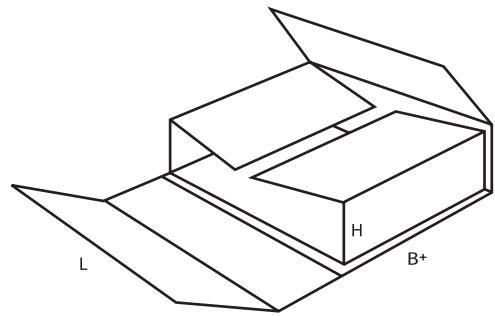
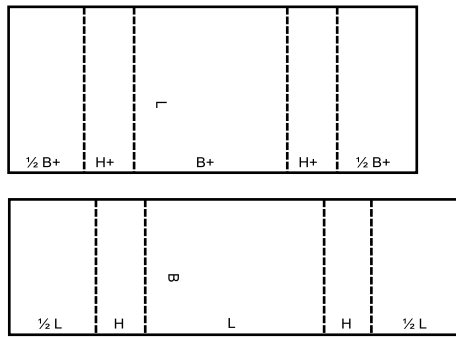

0405 M

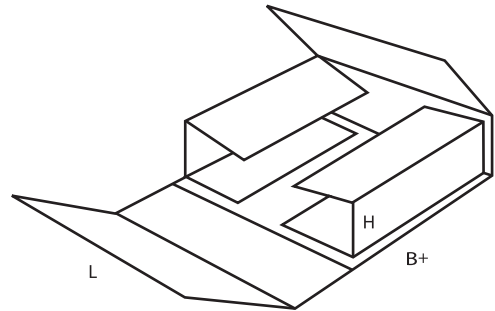
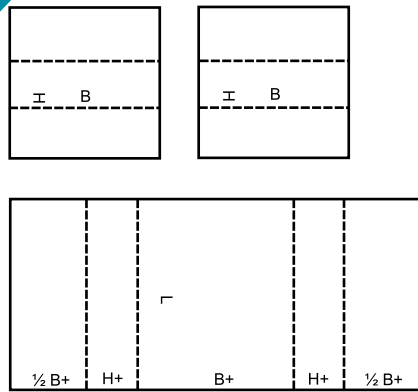

0406 A

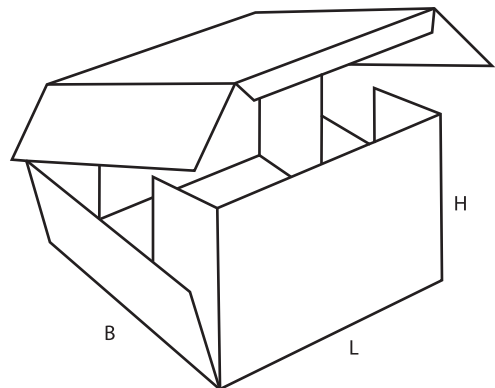
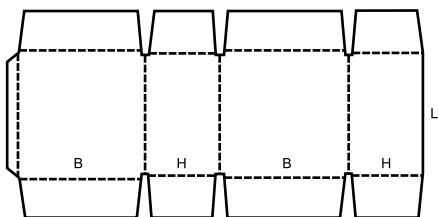

0409 M

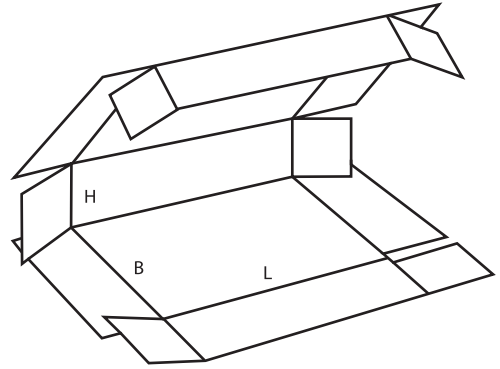
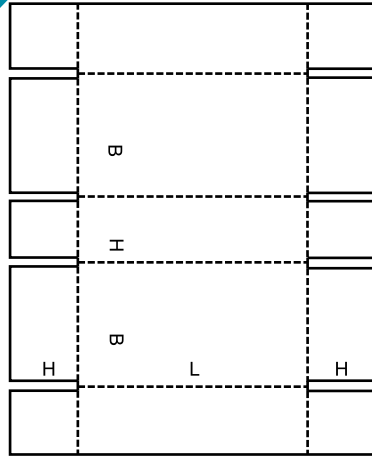

0410 M/A

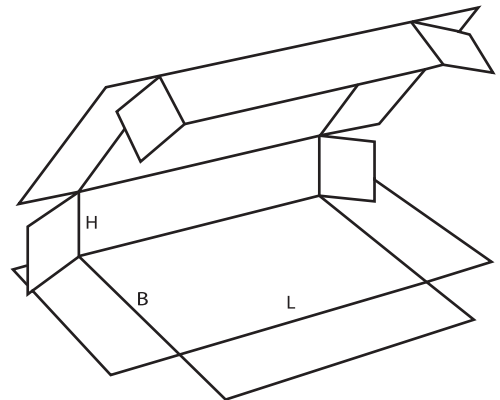
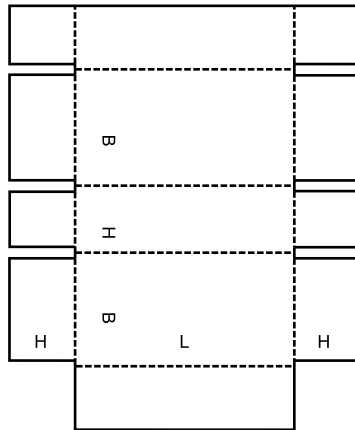

0411 M/A

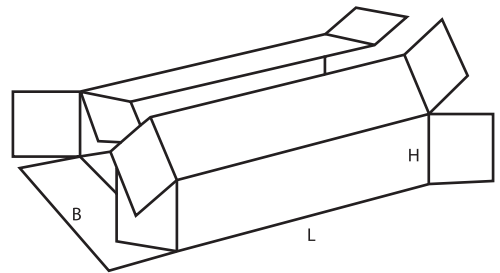
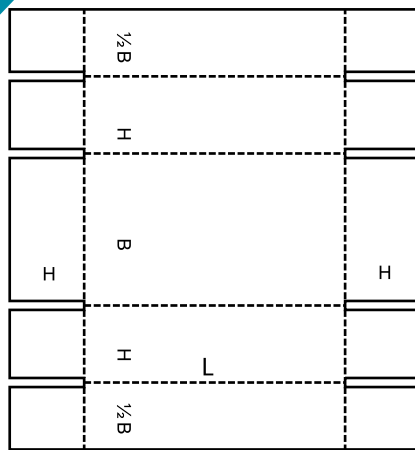

0412 M

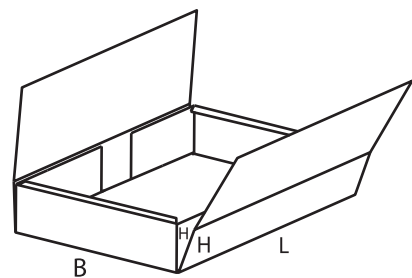
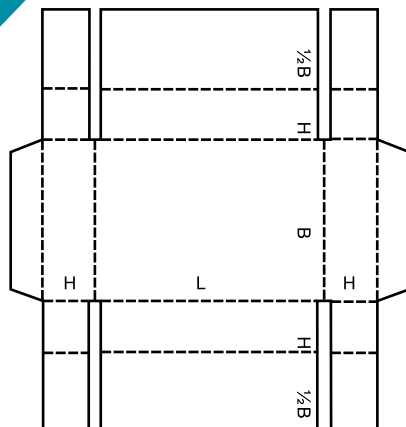

0413 M/A

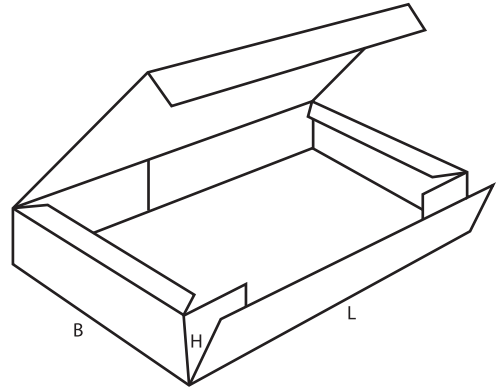
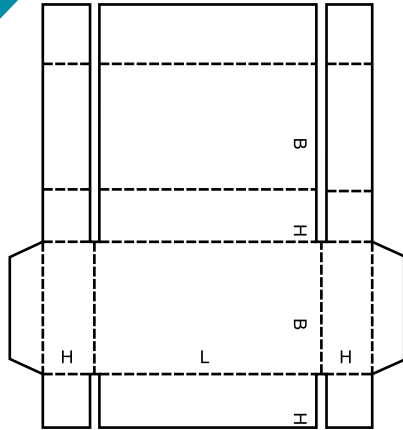

0415 M/A

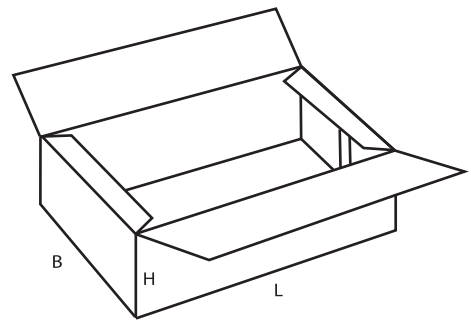
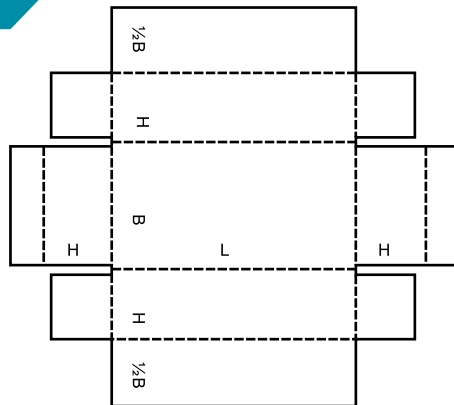

0416 M

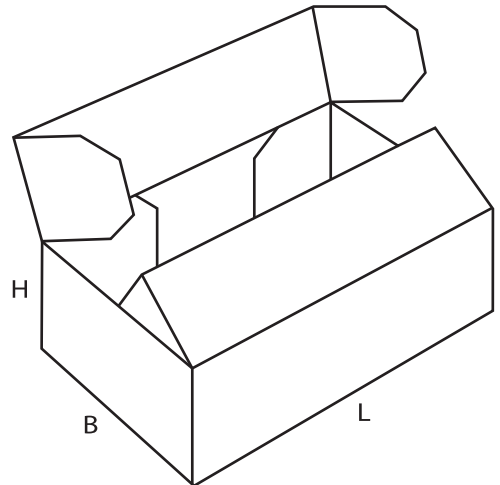
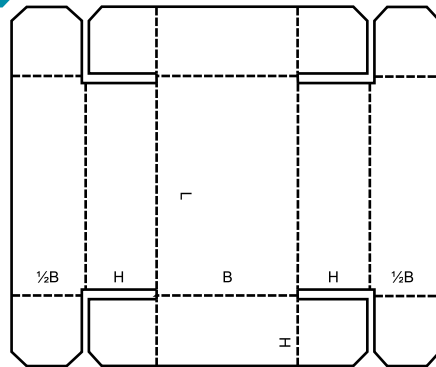

0420 M/A

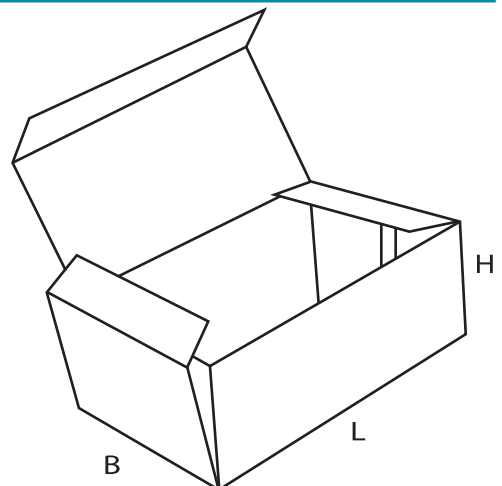
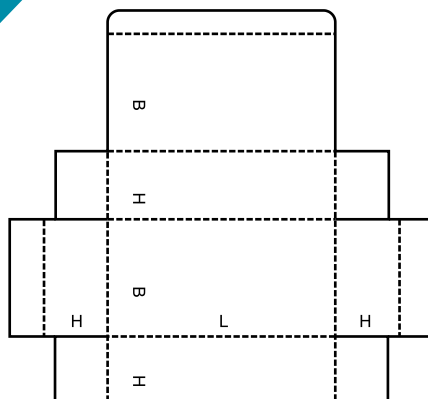

0421 M/A

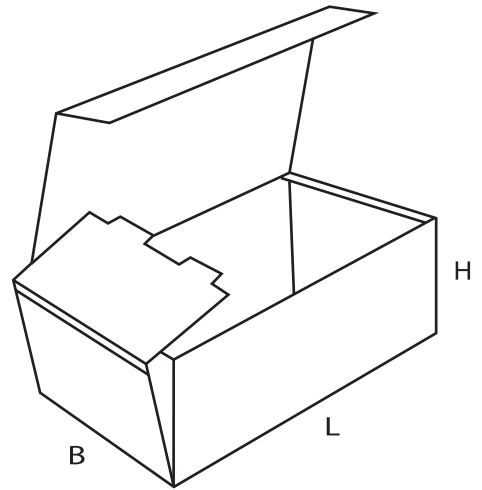
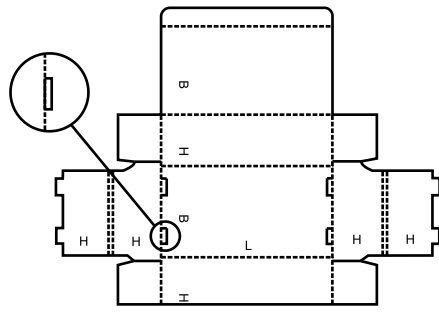

0422 M/A

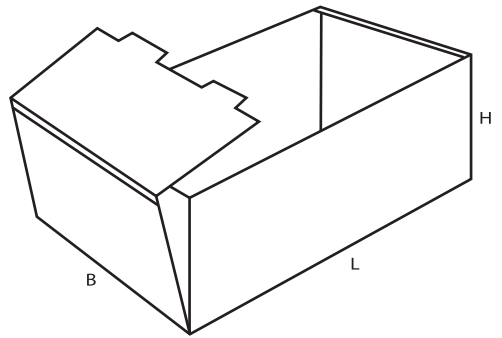
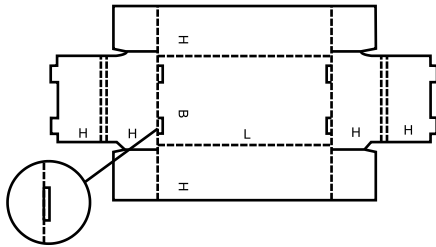

0423 M/A

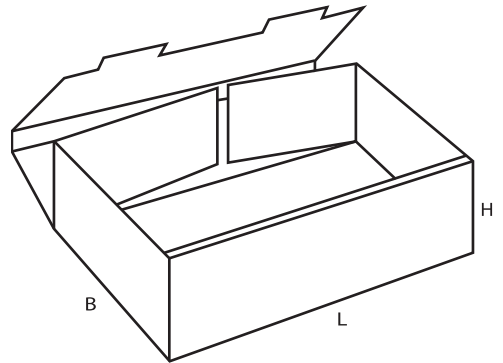
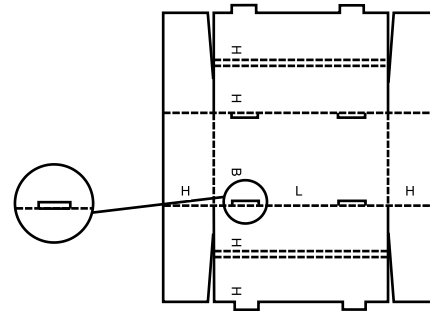

0424 M/A

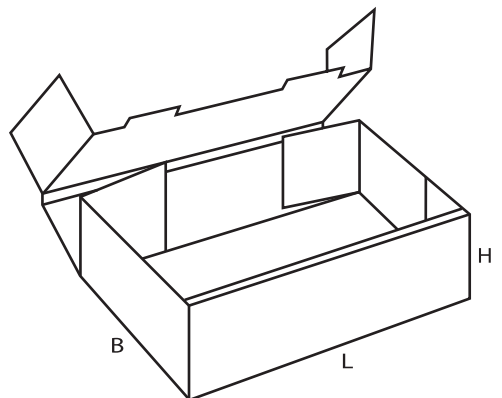
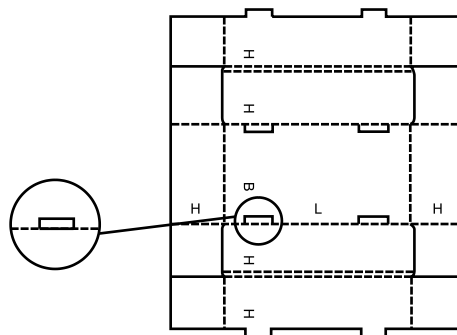

0425 M/A

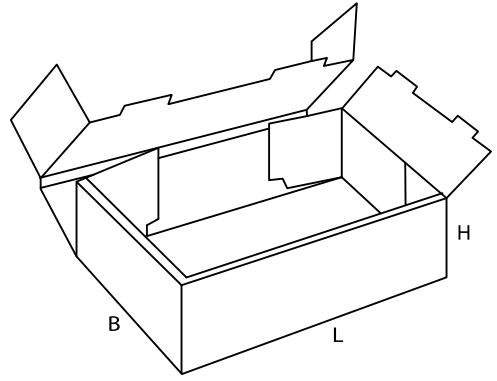
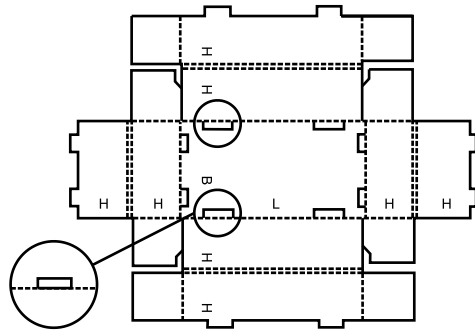

0426 M

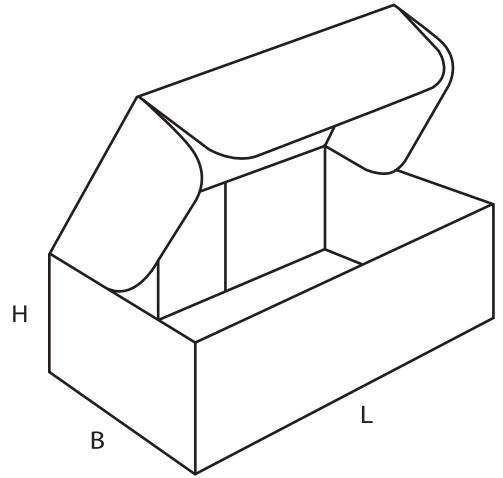
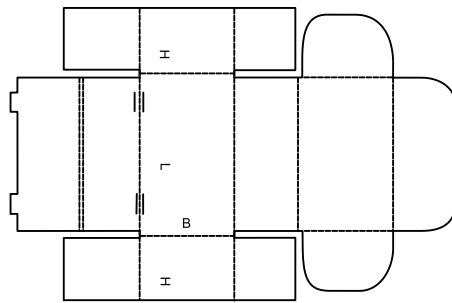

0427 M

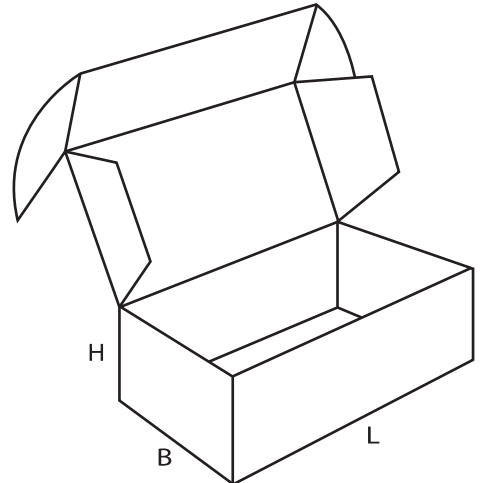
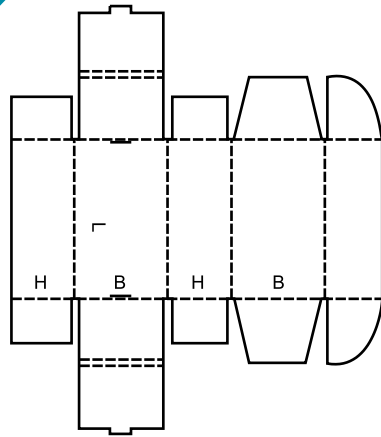

0428 M

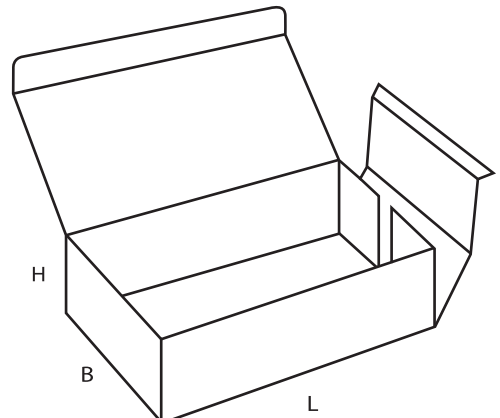
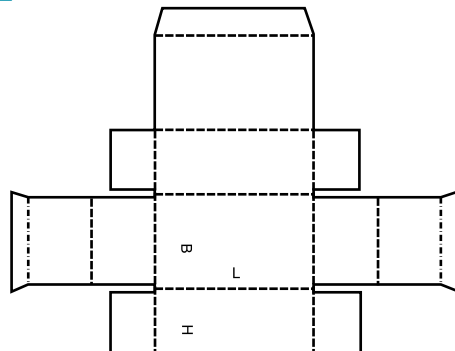

0429 M

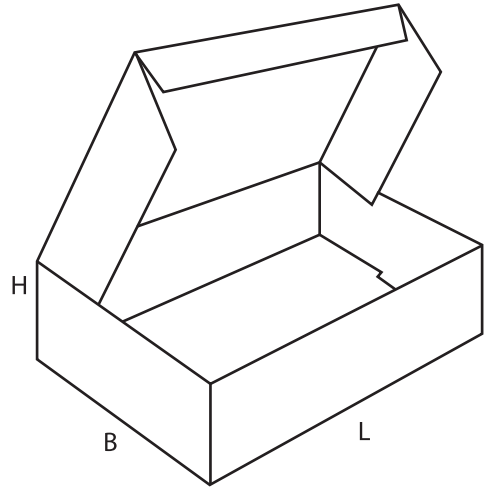
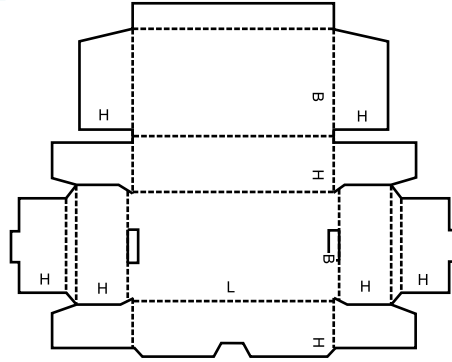

0430 M/A

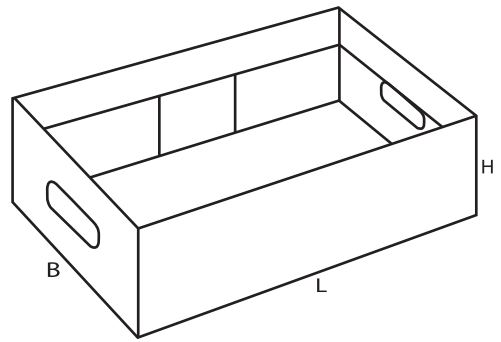
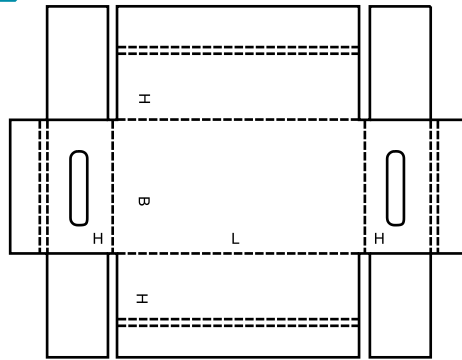

0431 M

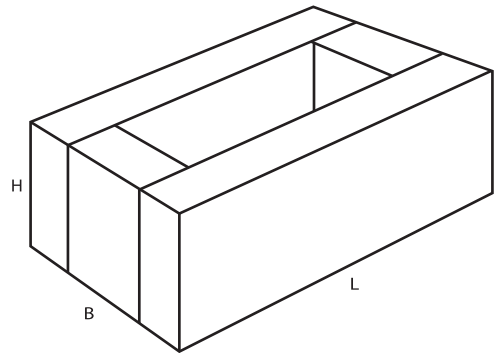
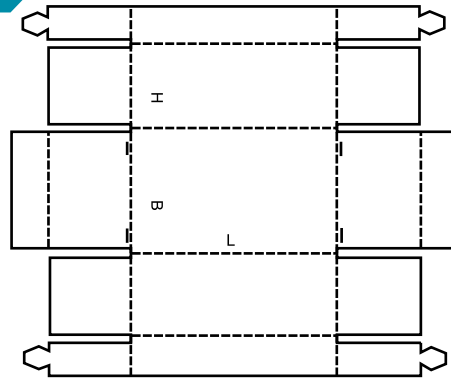

0432 M

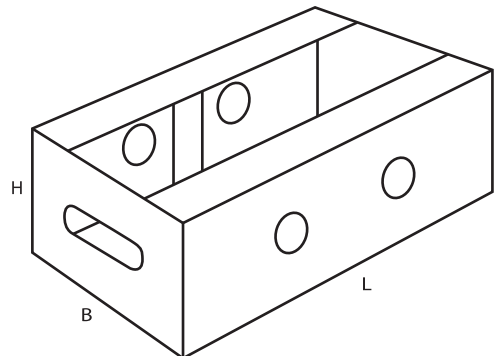
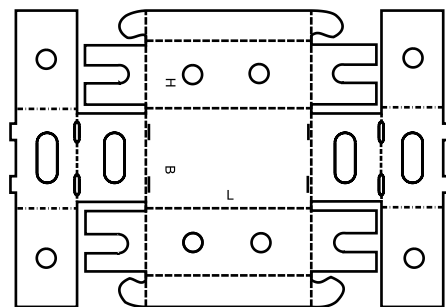

0433 M

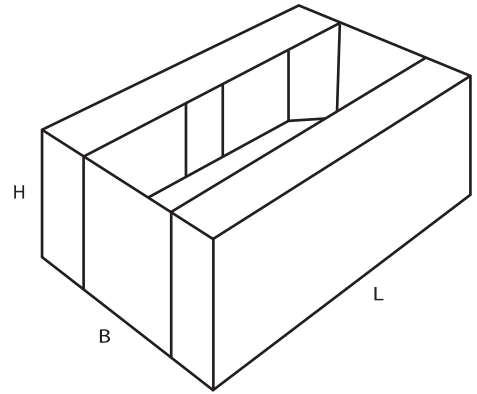
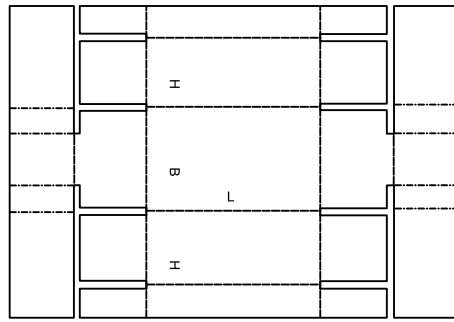

0434 M

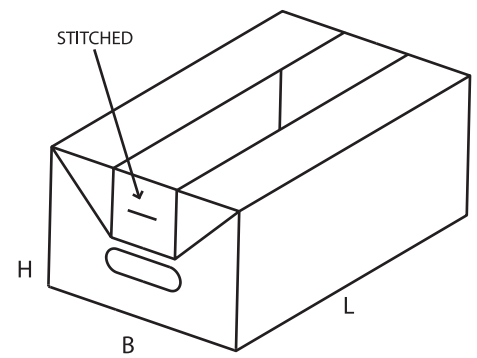
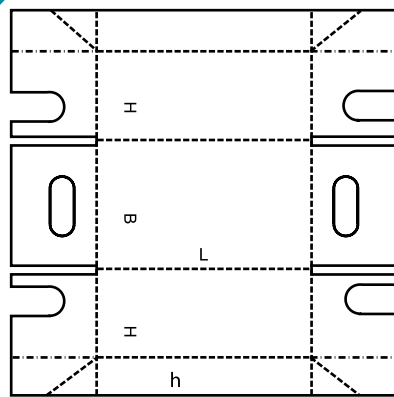

0435 M/A

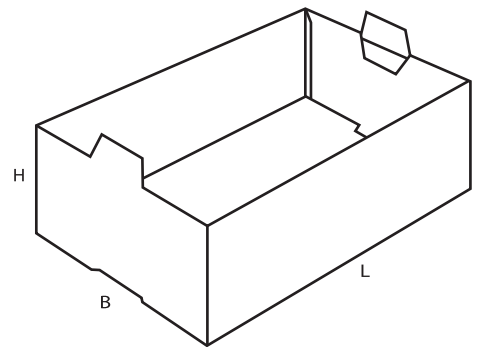
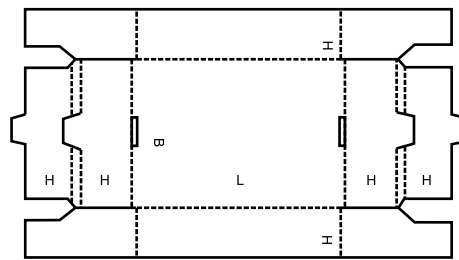

0436 M

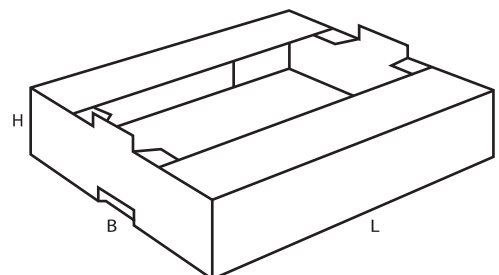
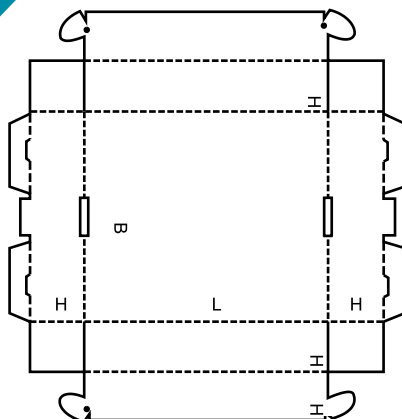

0437 M

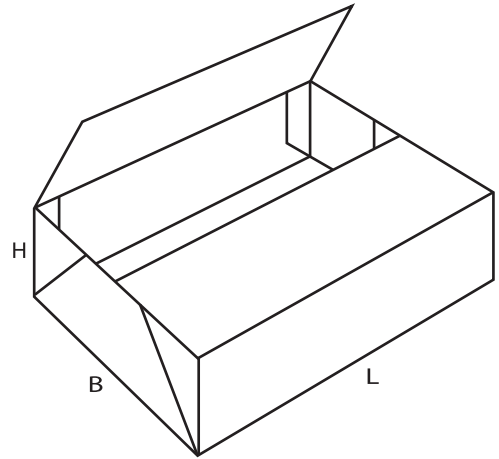
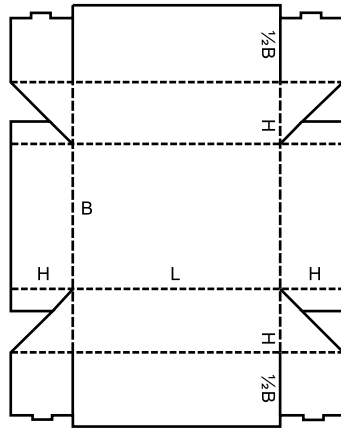

0440 A

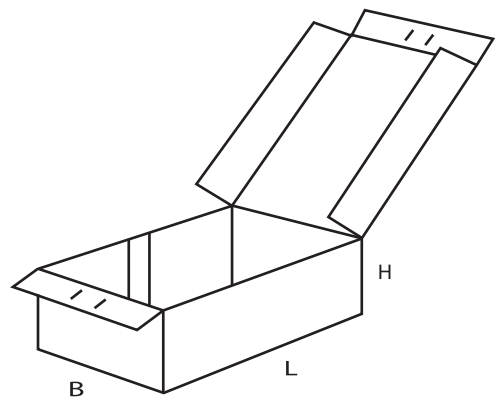
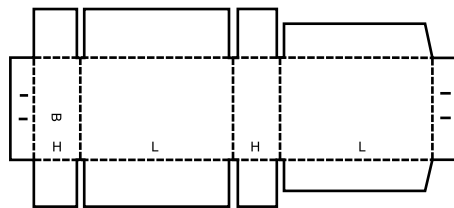

0441 A

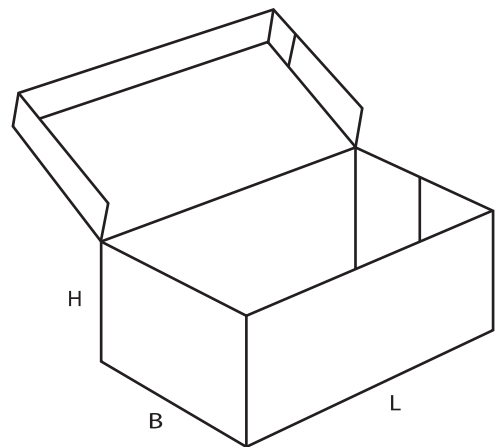
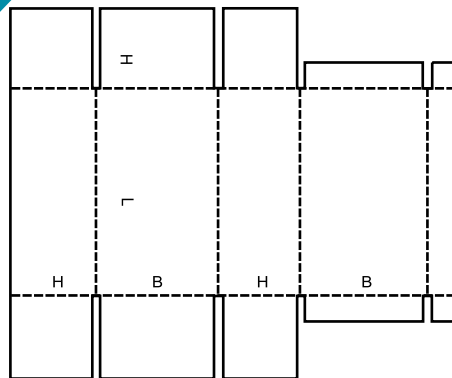

0442 M

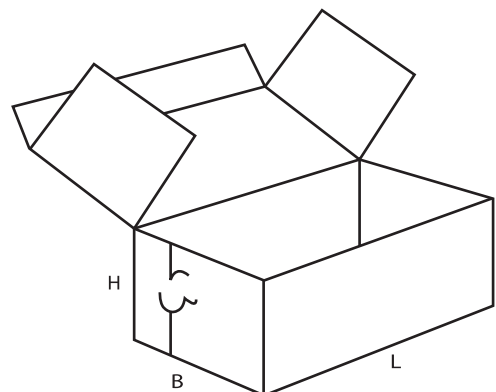
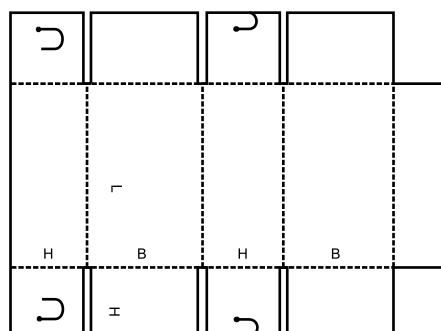

0443 M

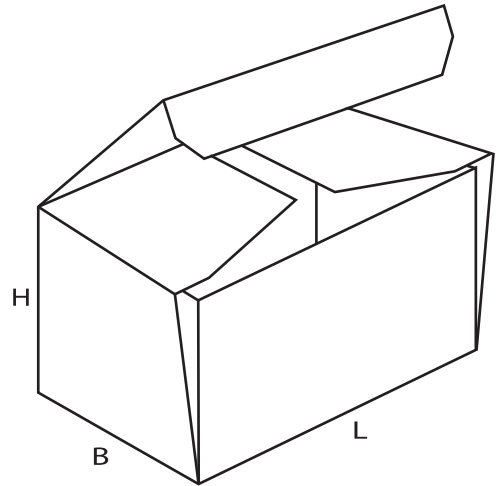
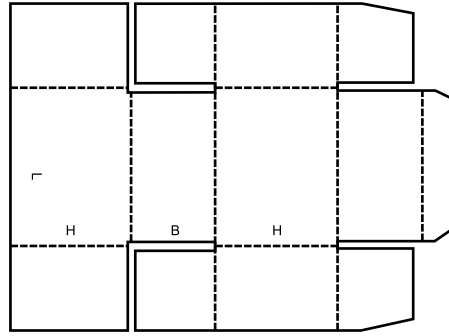

0444 M

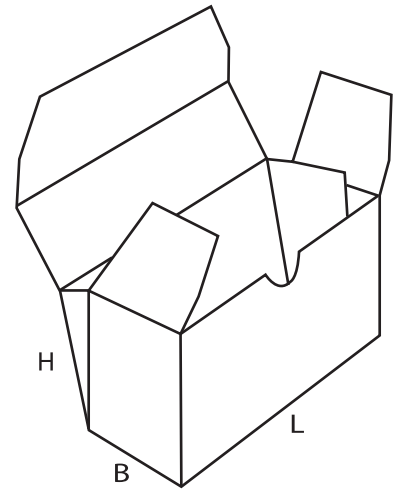
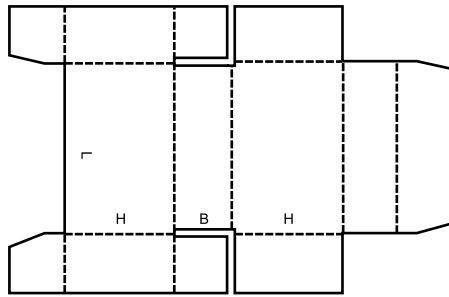

0445 M

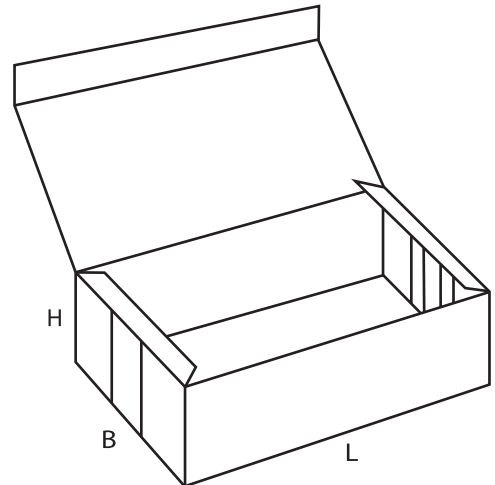
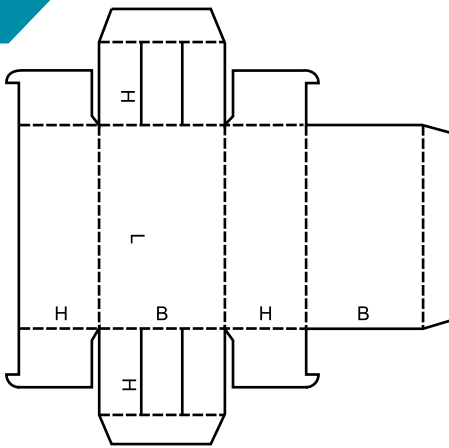

0446 A

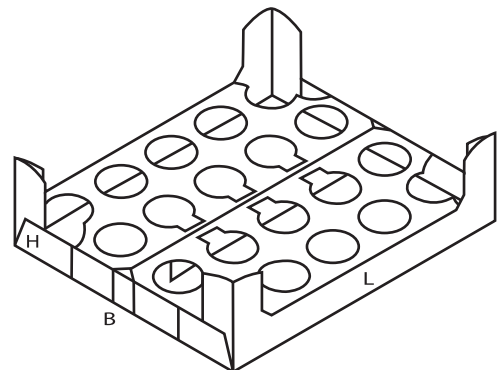
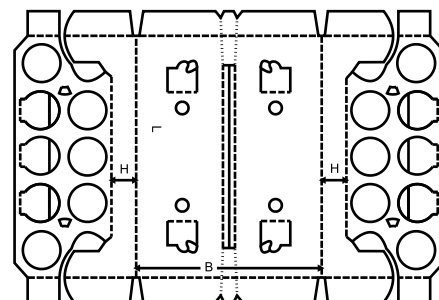

0447 M

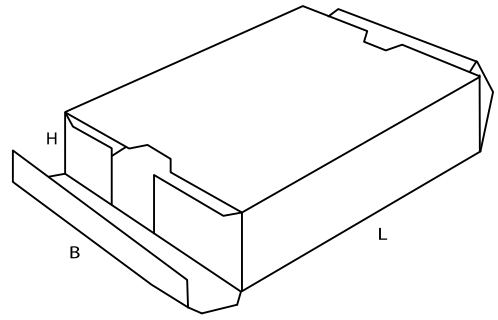
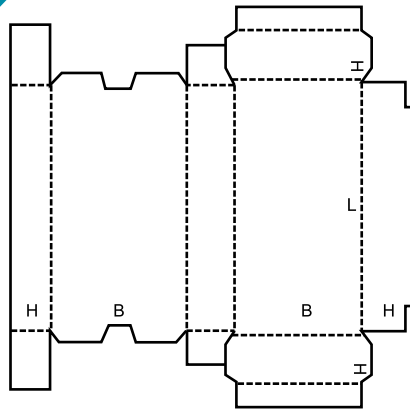

0448 M

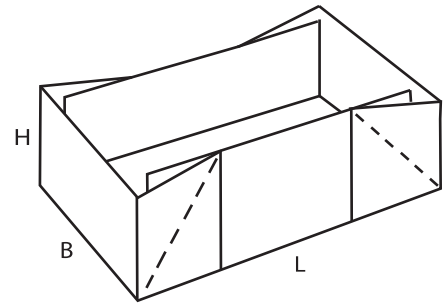
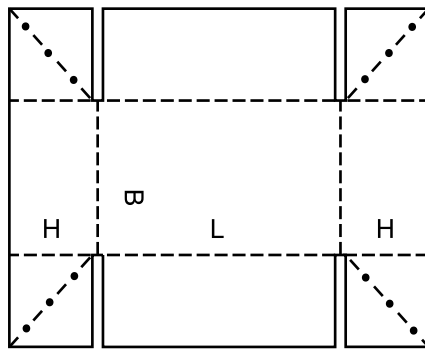

0449 M

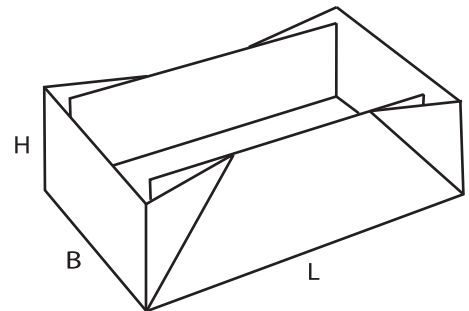
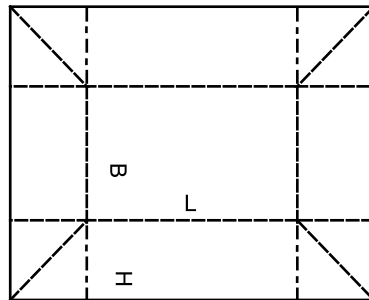

0450 M

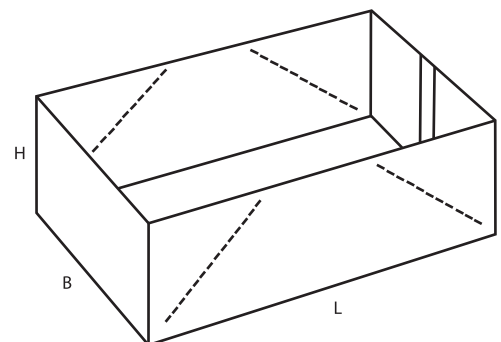
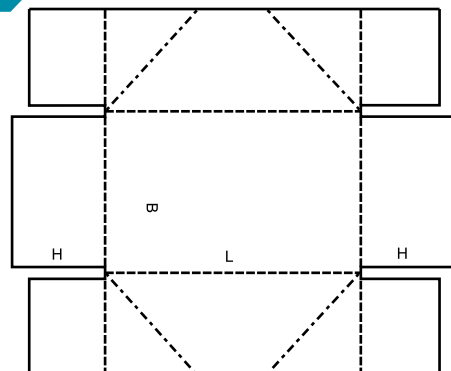

0451 M

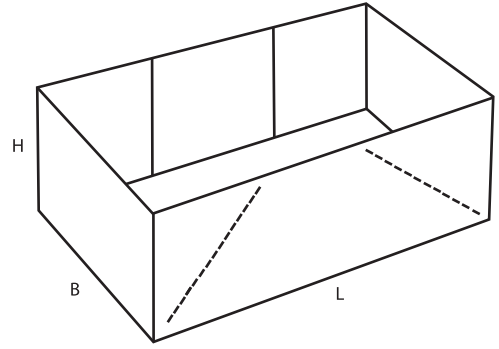
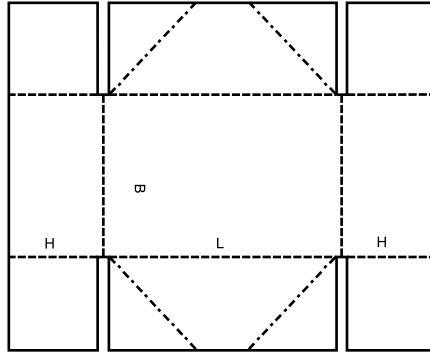

0452 A

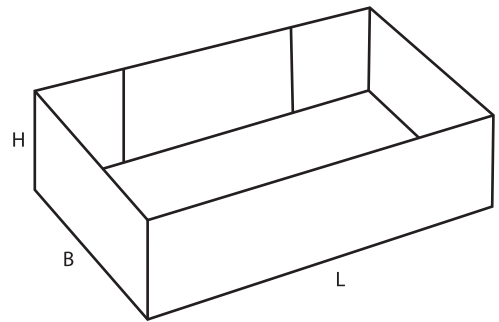
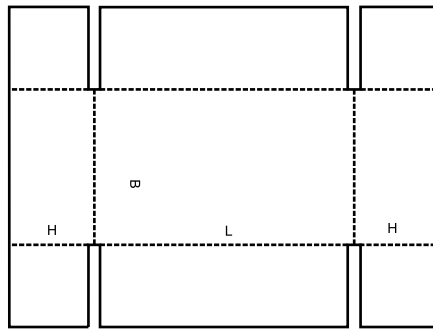

0453 A

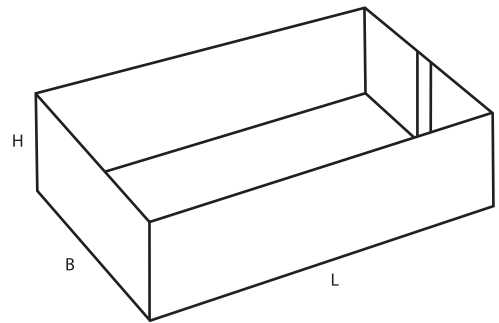
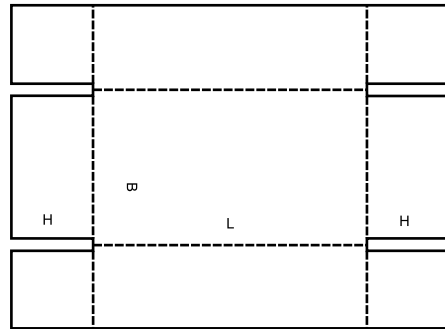

0454 M

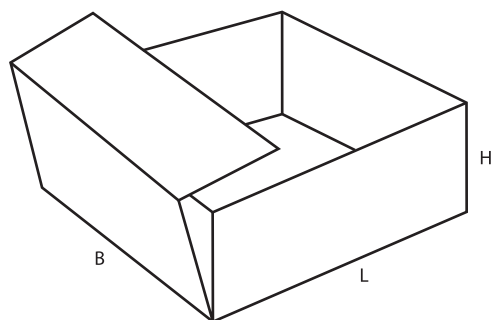
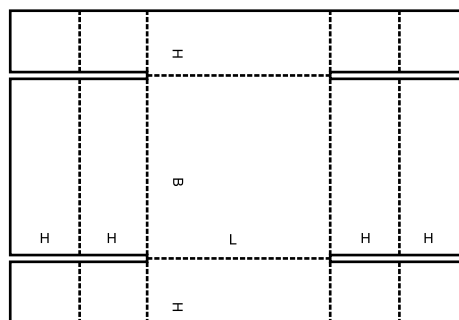

0455 M

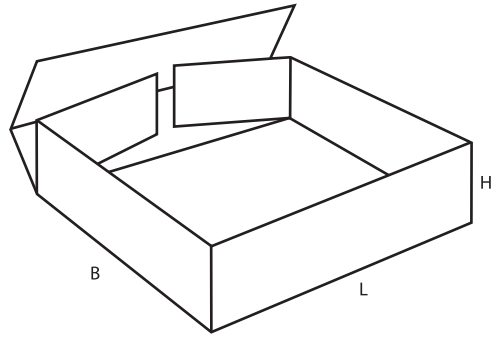
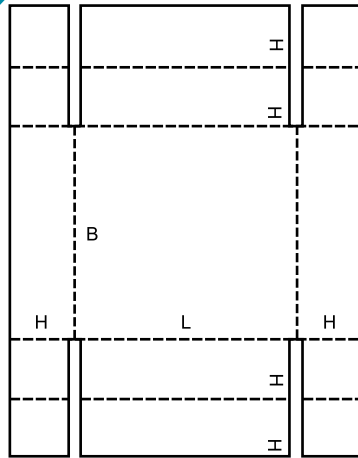

0456 M

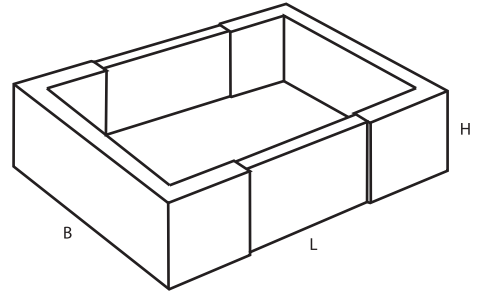
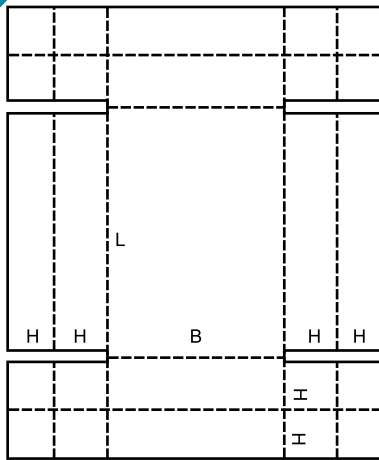

0457 M

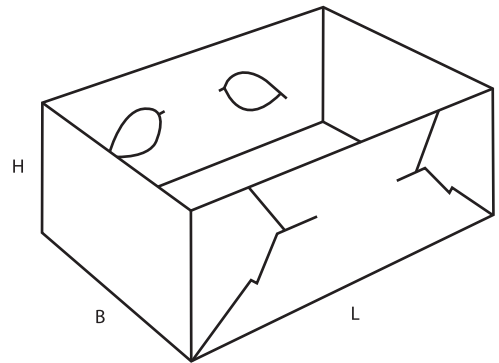
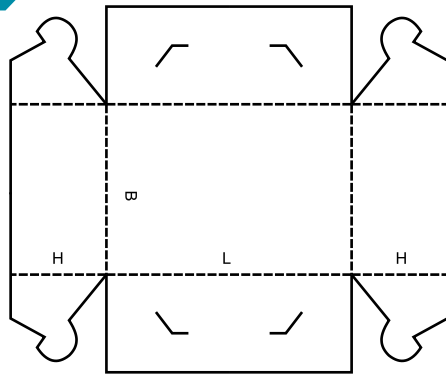

0458 M

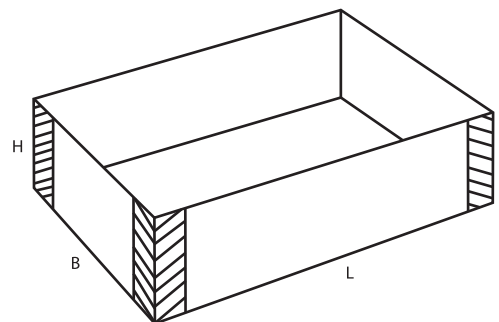
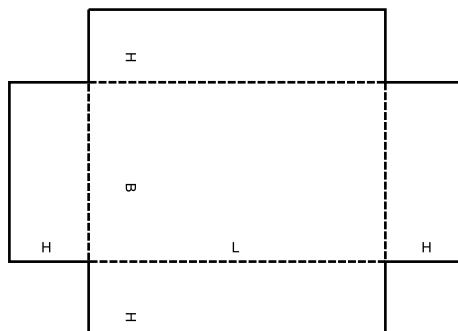

0459 A

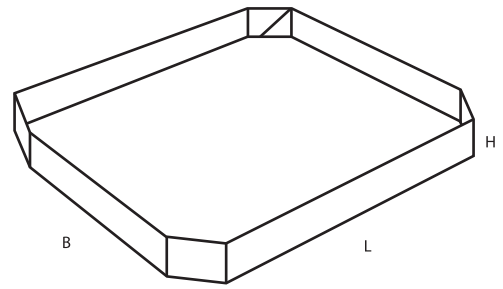
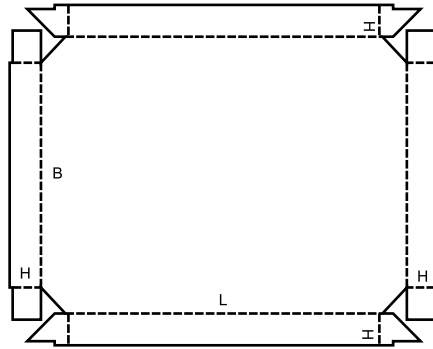

0460 A

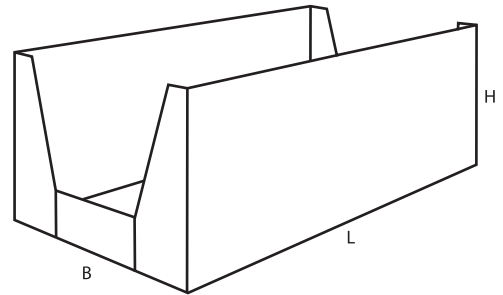
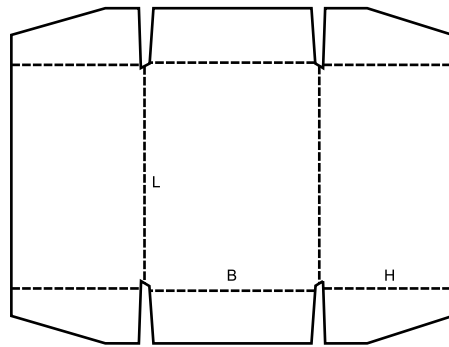

0470 M

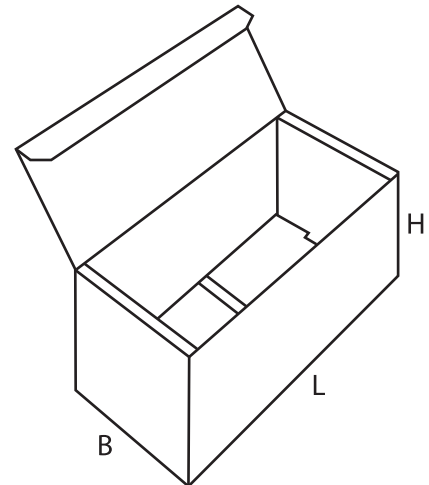
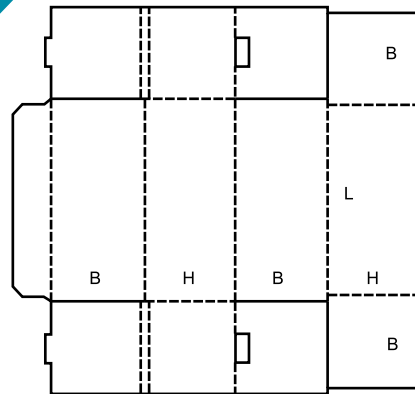

0471 M

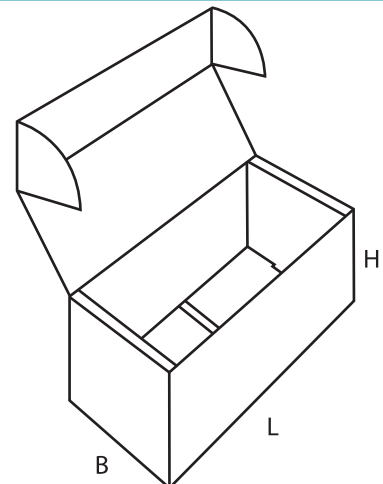
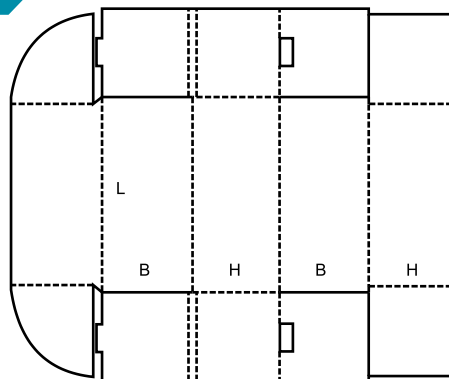

0472 M

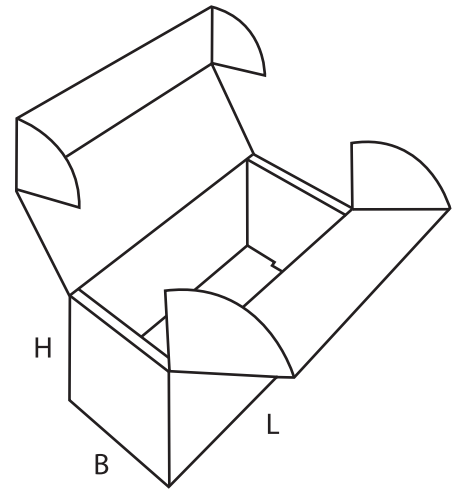
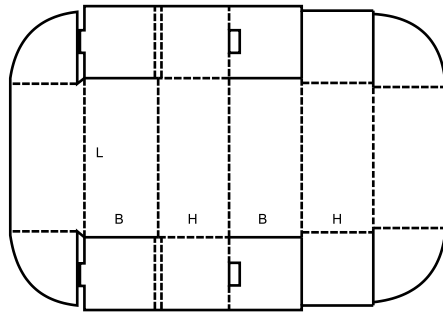

0473 M

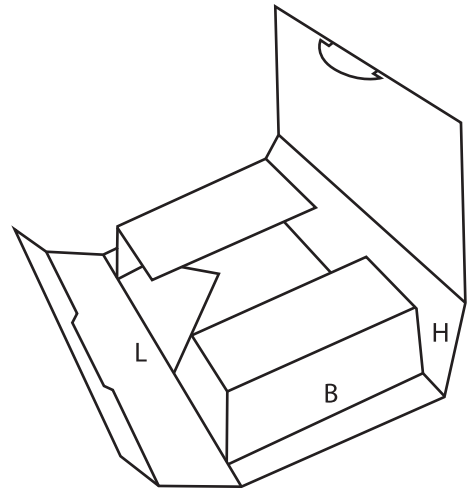
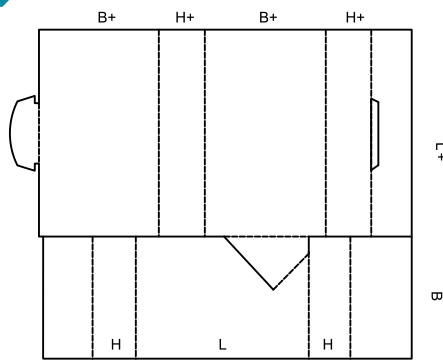

0480 A

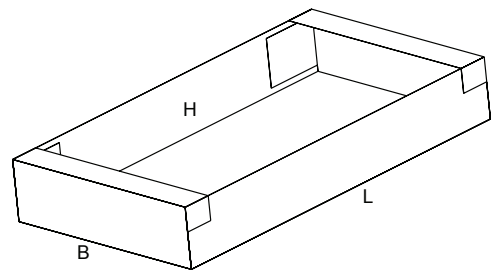
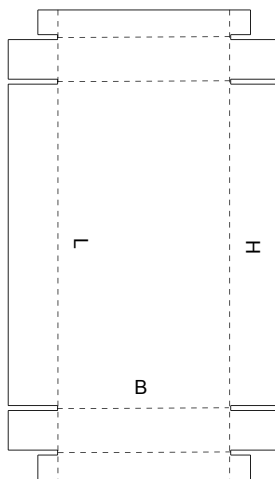

Tabs and slots should conform with the FEFCO Common Footprint standard (www.fefco.org).
The CF stamp can be downloaded from the FEFCO website.



0500

▲ **Slide-type boxes** consist of several pieces of liners and sleeves sliding in different directions into each other. This group also includes outside sleeves for other cases.

▲ **Boîtes coulissantes** constituées par plusieurs manchons coulissants rentrant en différentes directions les uns dans les autres. Ce groupe comprend aussi les manchons extérieurs pour d'autres caisses.

▲ **Schiebeschachteln (Gürtelschachteln)** bestehen aus mehreren in verschiedenen Richtungen ineinanderschließbaren Ringeinsätzen und Manschetten. Zu dieser Gruppe gehören auch Überschiebhülsen.

▲ **Scatole scorrevoli:** Contenitori telescopico composti da diversi pezzi che scorrono l'uno con l'altro. In questo gruppo sono incluse anche le fasce esterne per scatole.

▲ **Cajas de tipo deslizante:** constan de varias piezas de forros interiores y fundas que deslizan en diferentes direcciones uno dentro de otro. Este grupo incluye también fundas exteriores para otras cajas.

0501 M

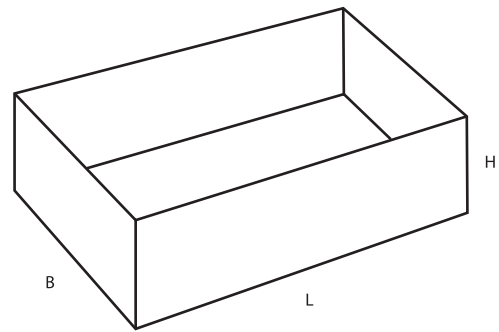
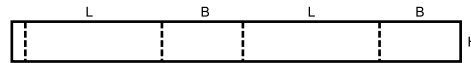

0502 M

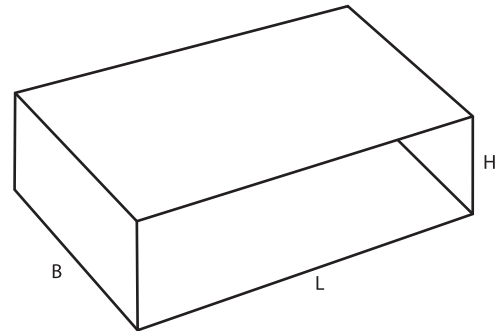
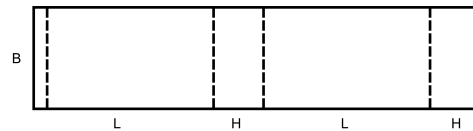

0503 M

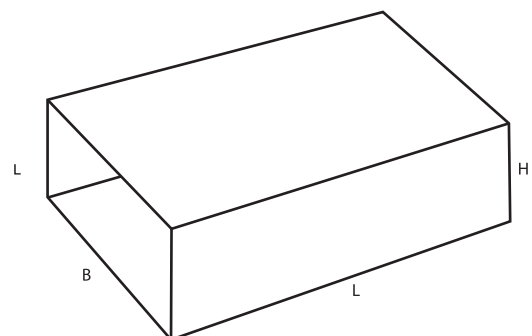
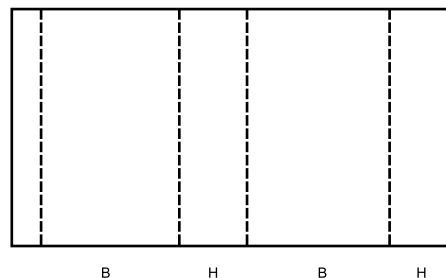

0504 M

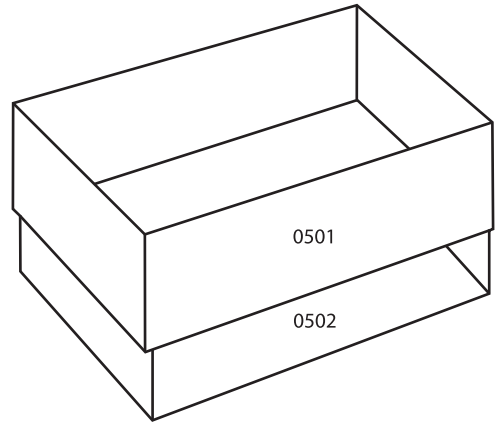
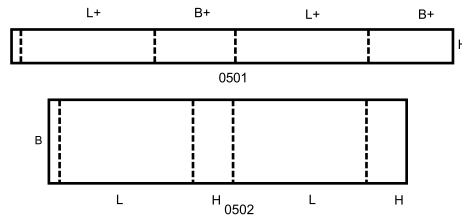

0505 M

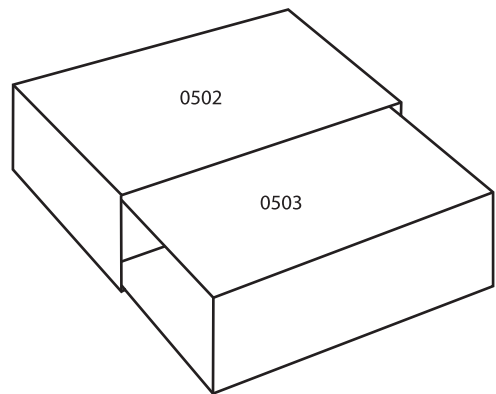
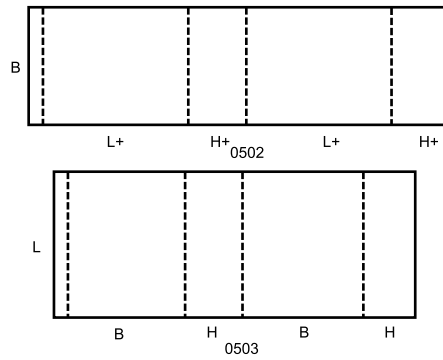

0507 M

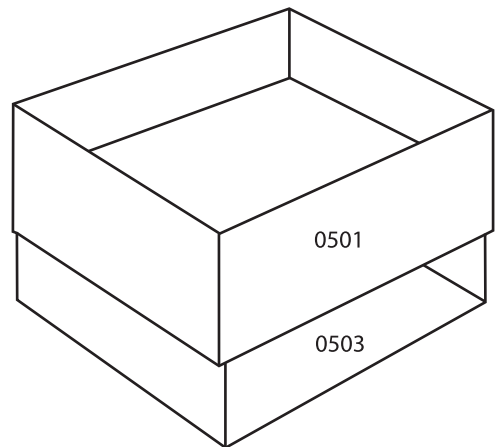
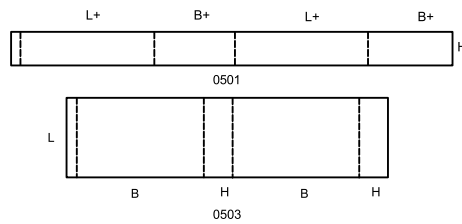

0509 M

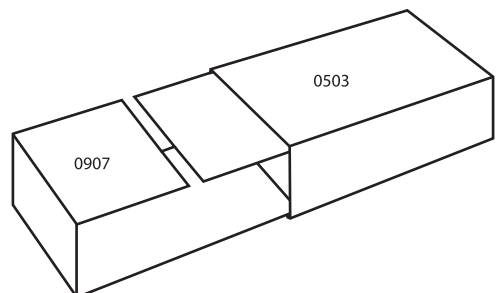
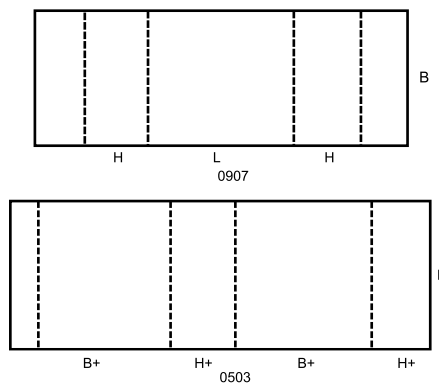

0510 M

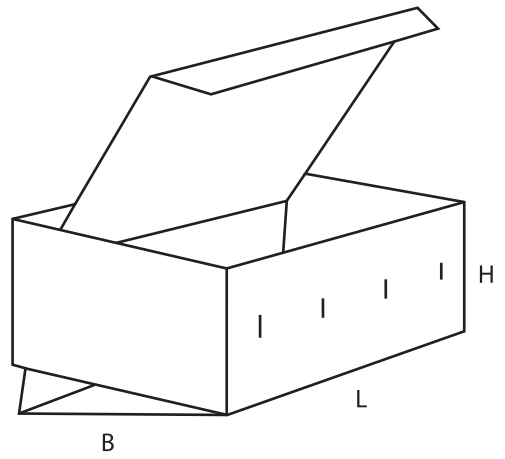
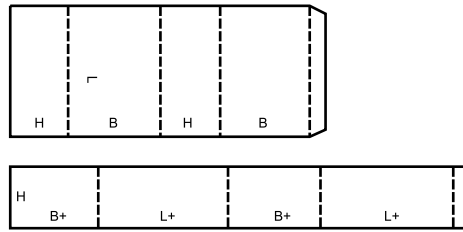

0511 M

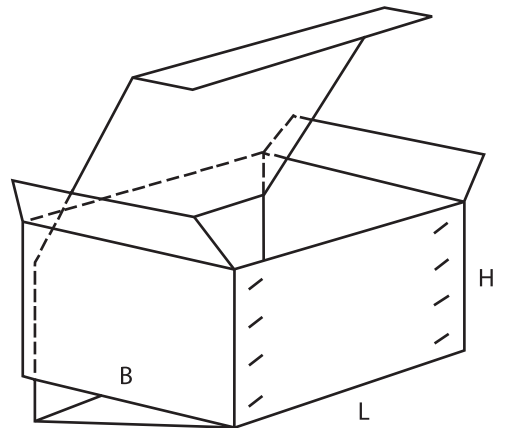
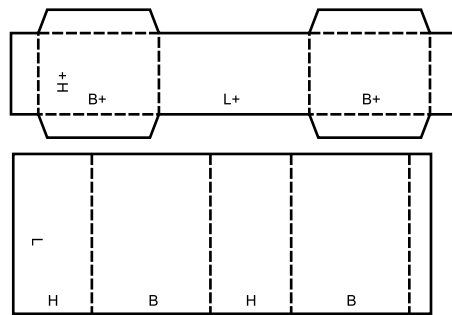

0512 M

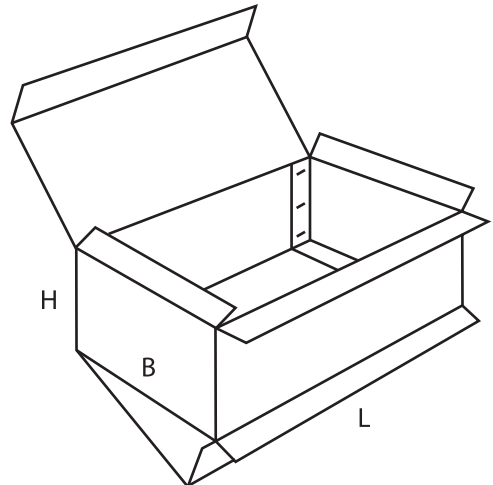
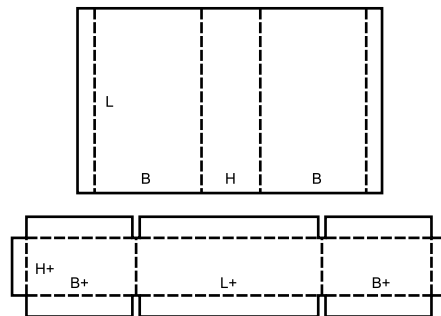

0600

▲ **Rigid-type boxes** consist of two separate end pieces and a body and require stitching or a similar operation before they can be used.

▲ **Caisses rigides** constituées de plusieurs pièces nécessitant un assemblage avant emploi.

▲ **Formfeste Schachteln** bestehen in der Regel aus zwei Seitenteilen und einem Mittelteil, das Boden und Dekkel bildet. Diese Schachteln können als vorbereitete Zuschnitte geliefert werden und sind dann vom Verbraucher durch Drahtheftung zu verbinden.

▲ **Casse rigide:** Imballaggi rigidi composti da due pezzi laterali separati e un corpo, e richiedono una fase di cucitura o altro prima di essere utilizzati.

▲ **Cajas de tipo rígidas:** formadas por dos piezas separadas, para los extremos y un cuerpo; requieren un grapado u otra operación similar antes de que puedan utilizarse.

0601 A

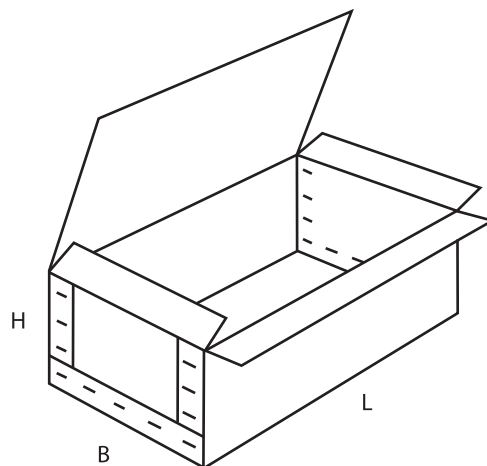
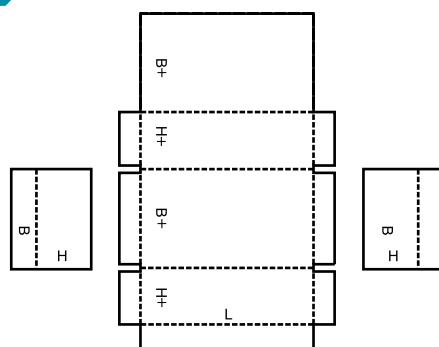

0602 A

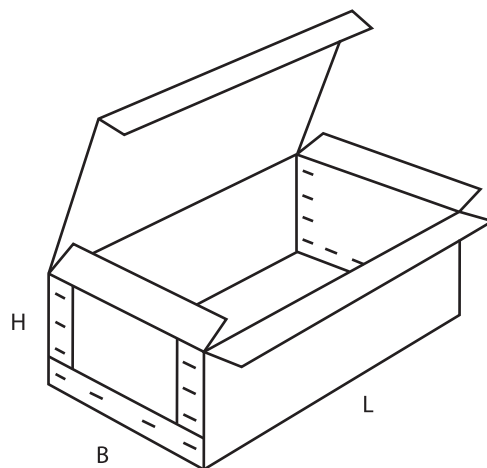
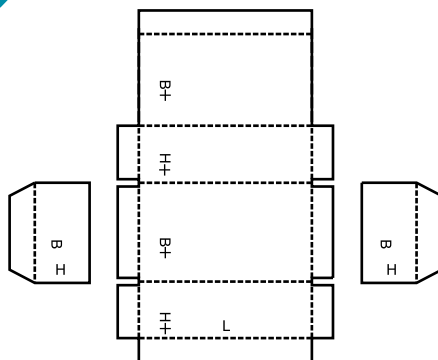

0605 A

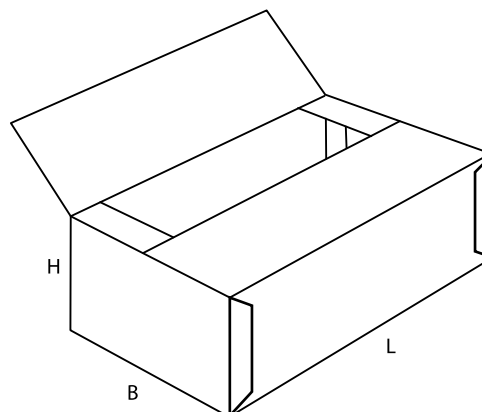
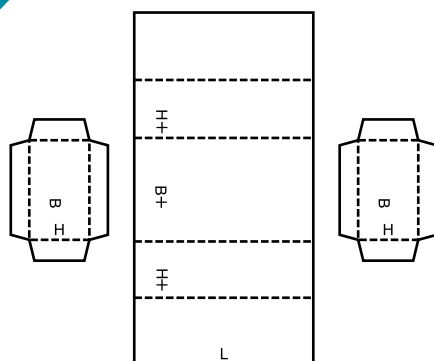

0606 A

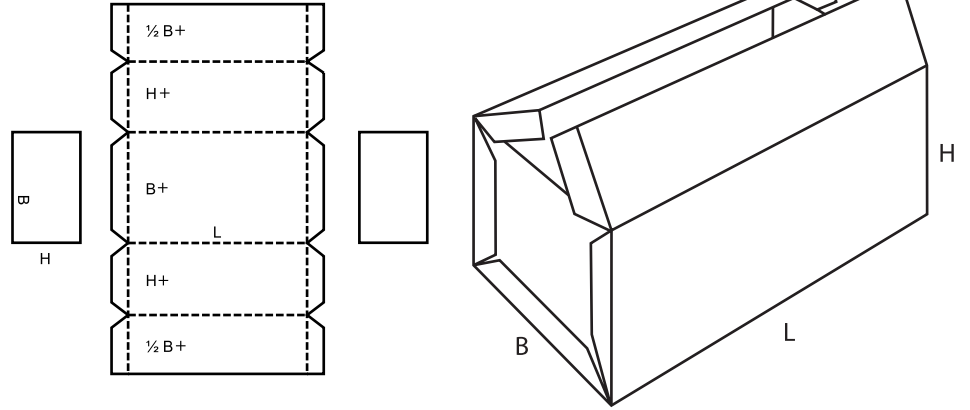

0607 A

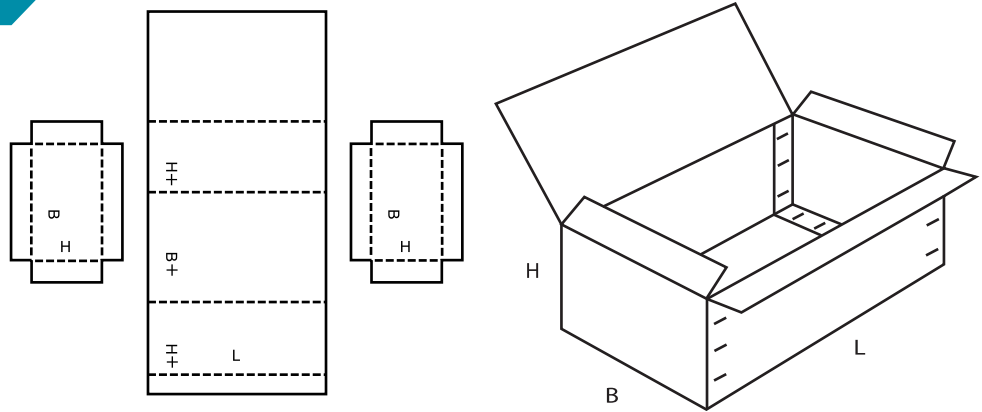

0608 A

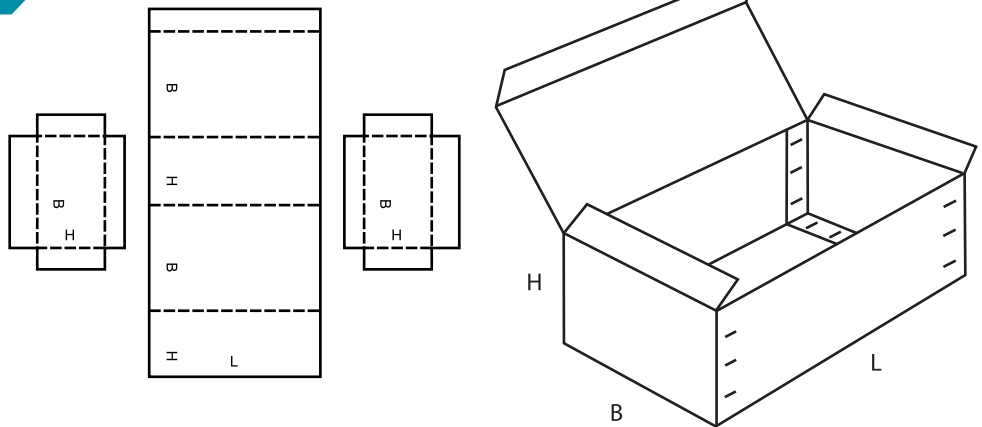

0610 M/A

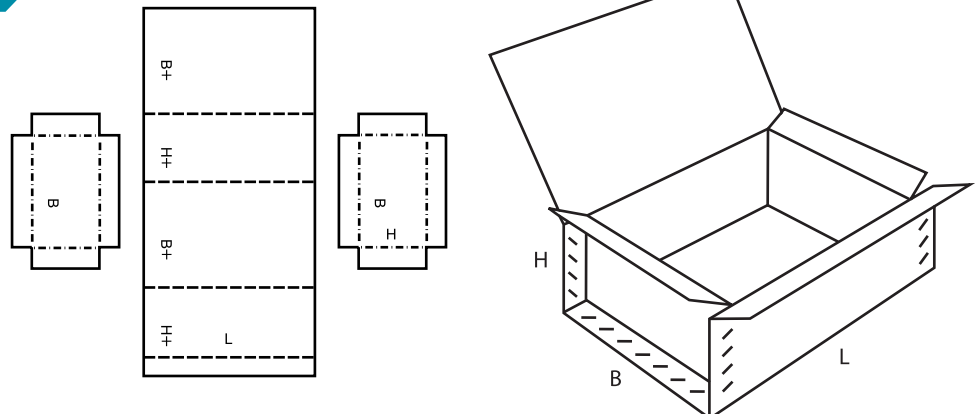

0615 M/A

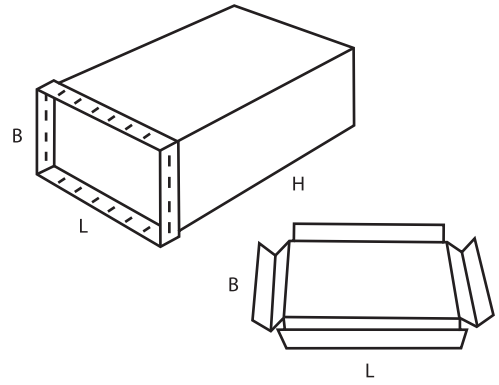
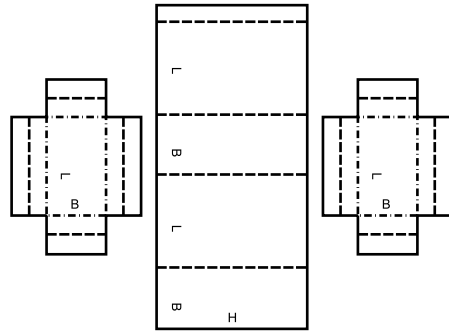

0616 M/A

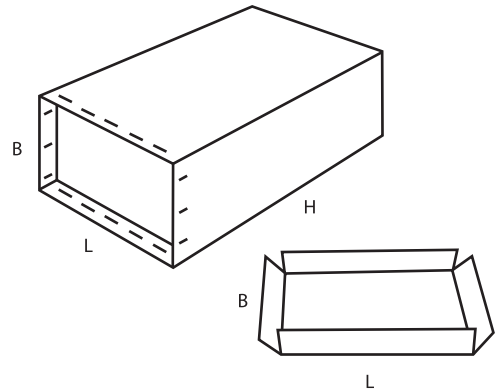
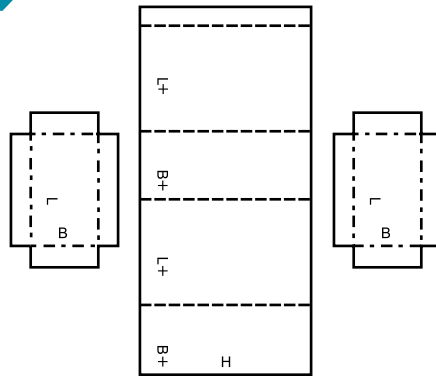

0620 A

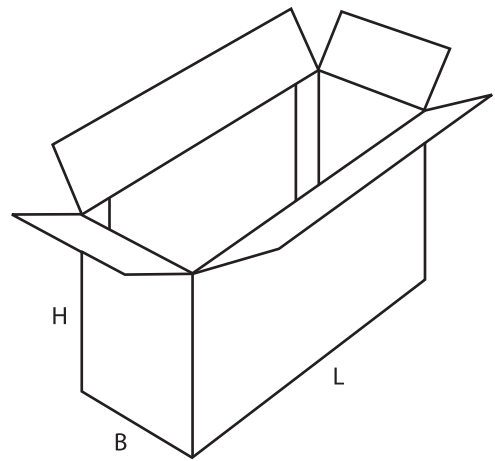
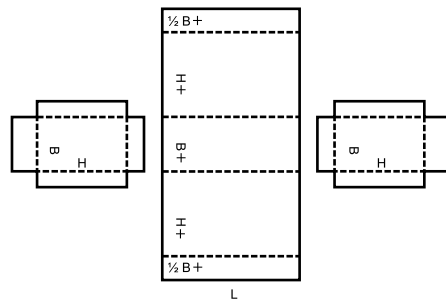

0621 M

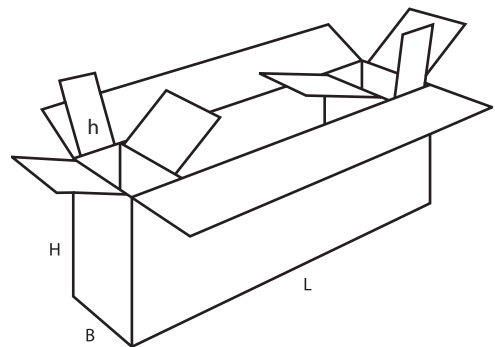
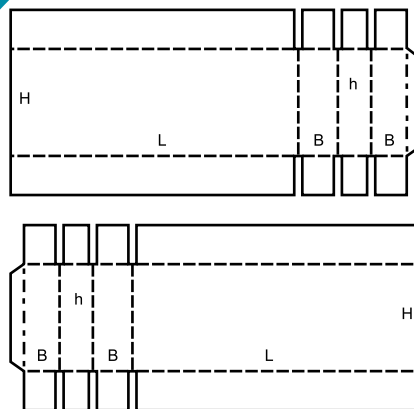

0700

- ▲ **Ready-glued** cases consist of basically one piece, are shipped flat and ready to use by simple setting up.
- ▲ **Caisses collées** prêtes à l'emploi, constituées en principe par une seule pièce, livrées à plat et prêtes à l'emploi après un simple montage.
- ▲ **Fertig geklebte** Schachteln sind einteilige, faltbare Schachteln, die zusammengelegt geliefert und durch einfaches Aufrichten gebrauchsfertig aufgestellt werden. Die Schachteln können mit einem Faldboden (Faldbodenschachtel) oder mit Diagonalbiegung (Aufrichteschachtel) ausgerüstet sein.

- ▲ **Casse incollate e pronte all'uso:** Imballaggi incollati già pronti composti in genere da un pezzo, sono consegnati piegati e sono pronti per l'uso tramite una semplice fase di montaggio apertura.
- ▲ **Cajas de encolado rápido:** están hechas generalmente de una sola pieza, se entregan extendidas en un plano o plegadas y listas para su utilización por medio de un sencillo montaje.

0700 M

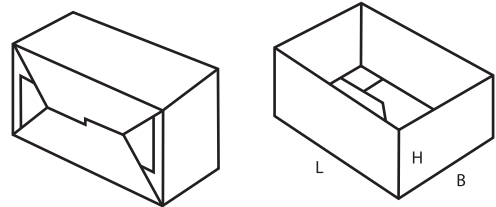
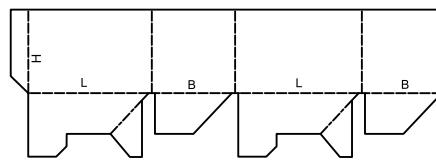

0701 M

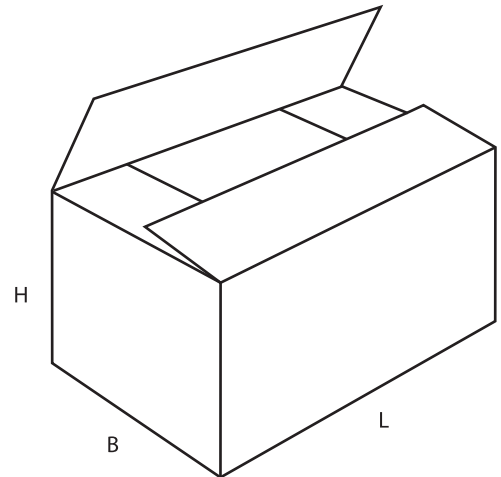
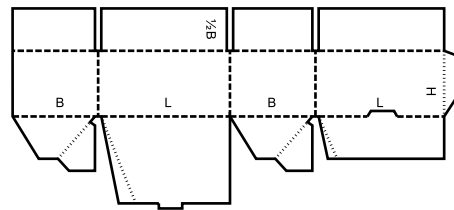

0703 M

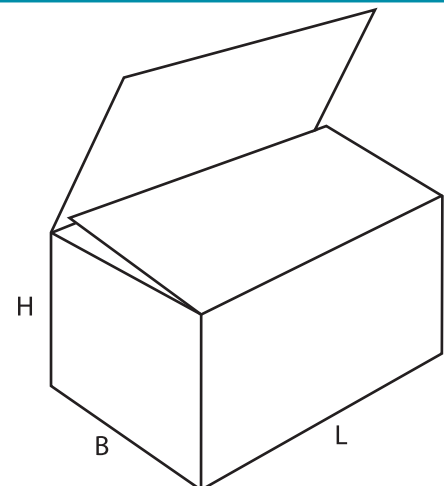
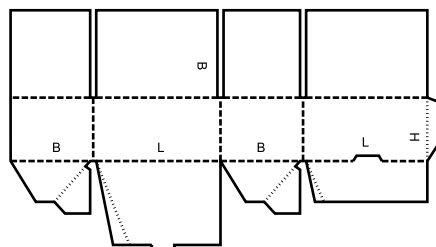

0711

M

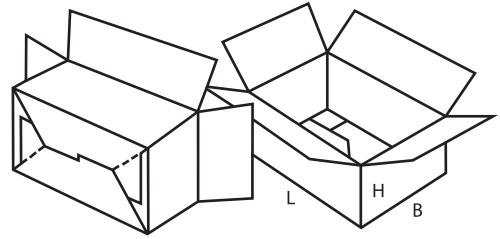
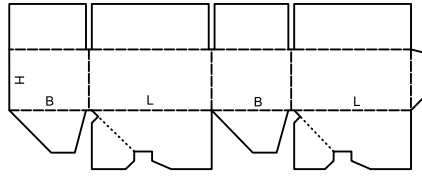

0712

M

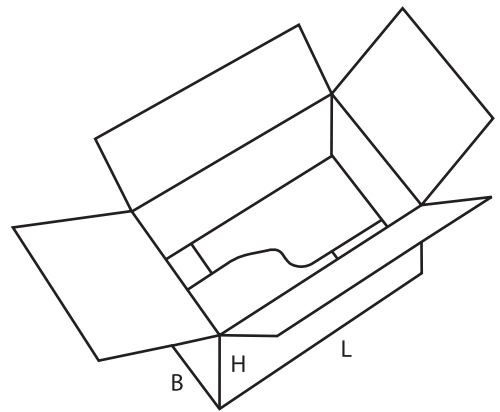
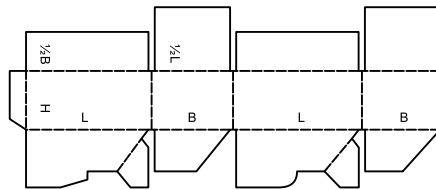

0713

M

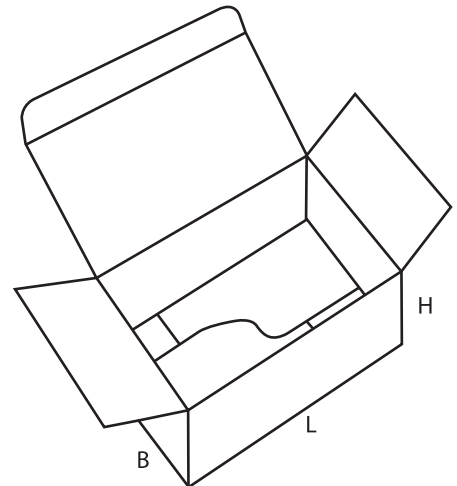
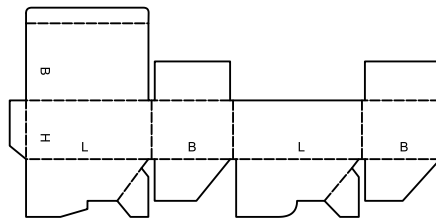

0714

M

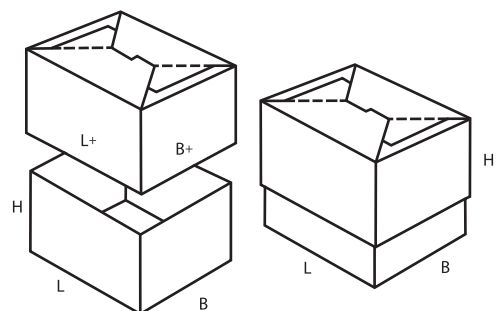
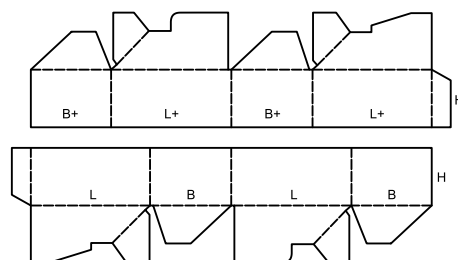

0715 M

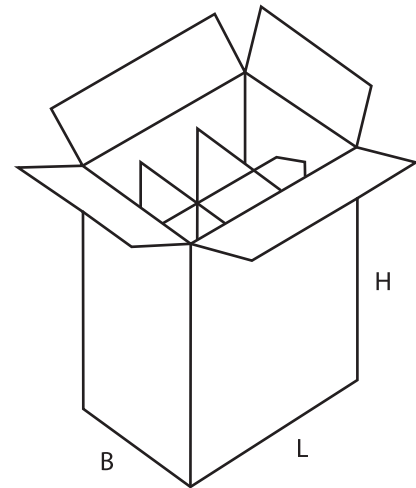
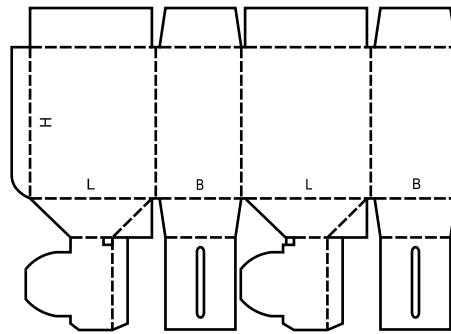

0716 M

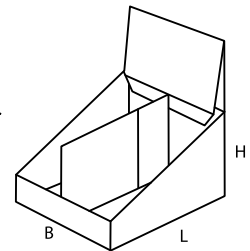
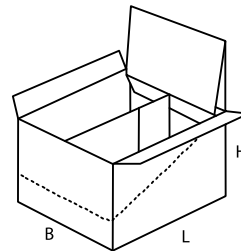
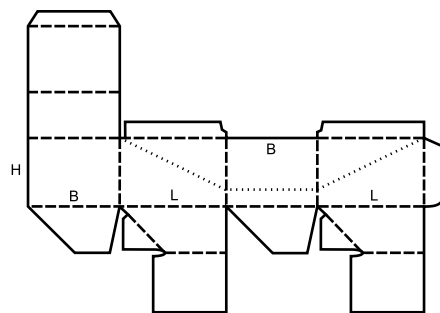

0717 M

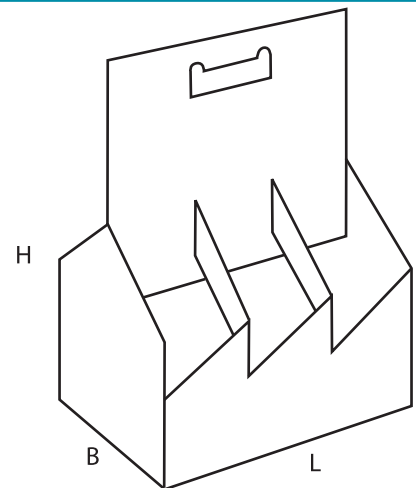
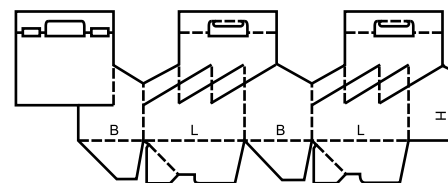

0718 M

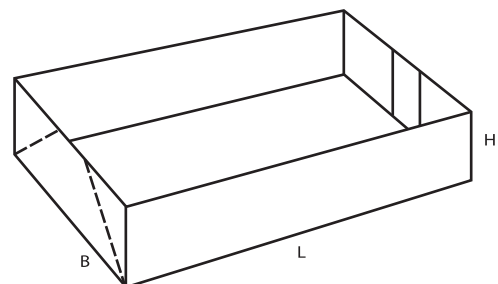
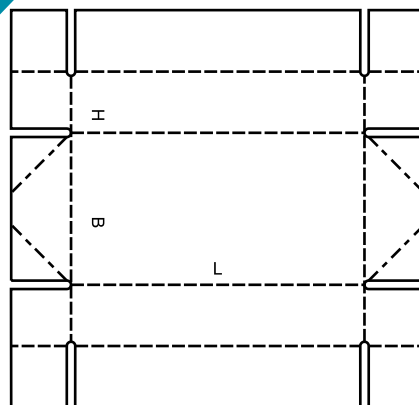

$B \geq 2H$

0747 M

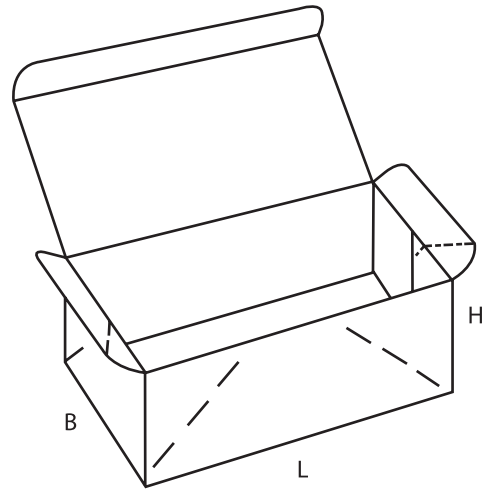
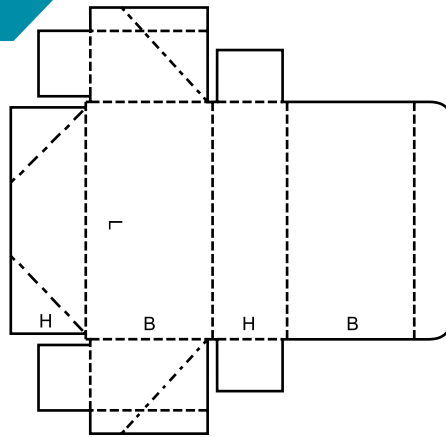

0748 M

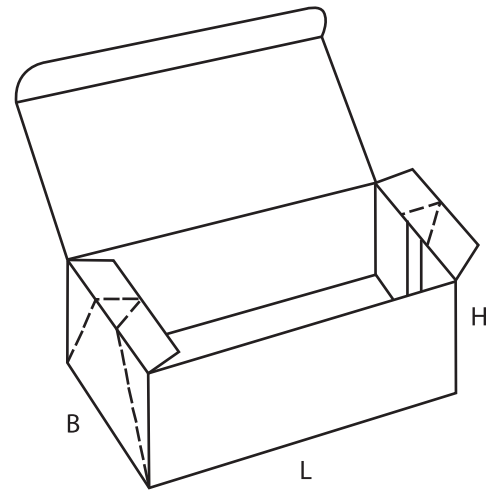
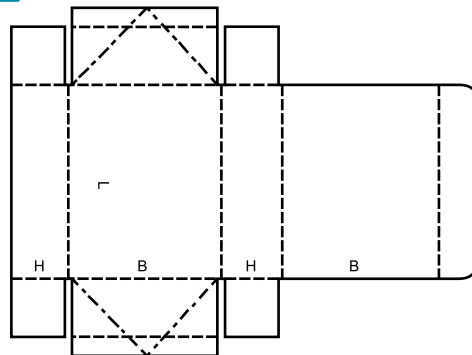

0751 M

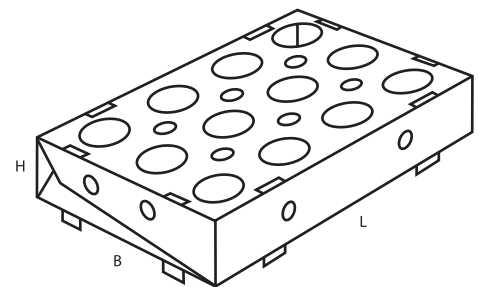
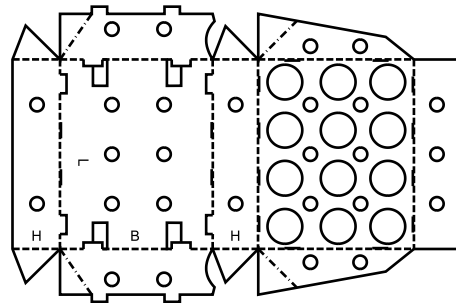

0752 M/A

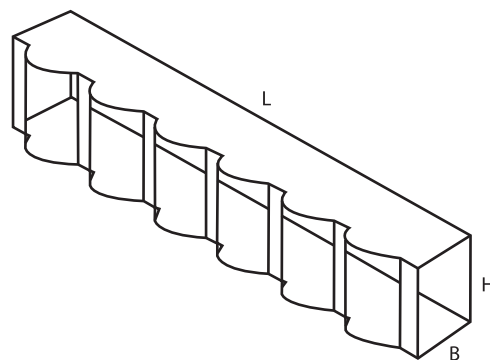
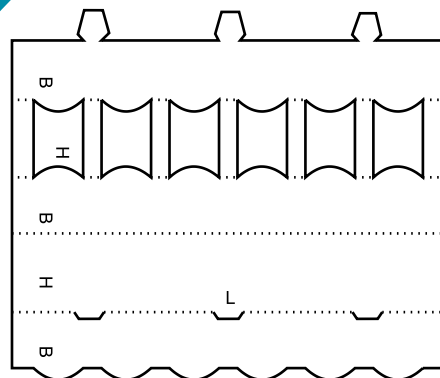

0759 M

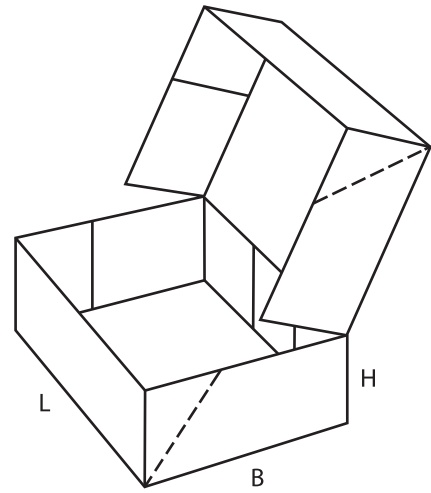
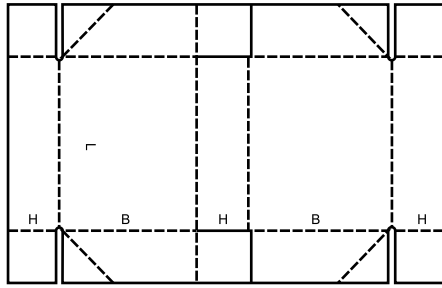

0761 M

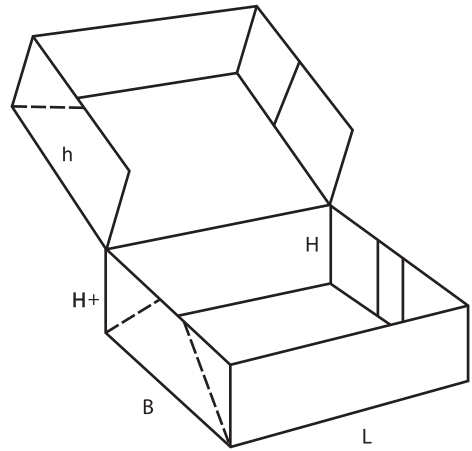
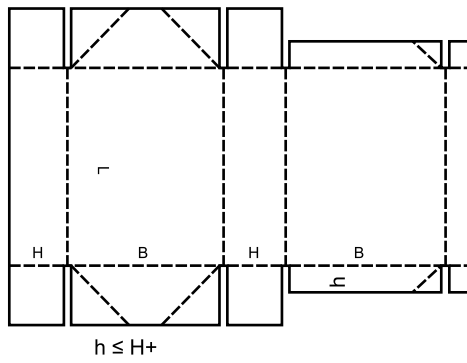

0770 M

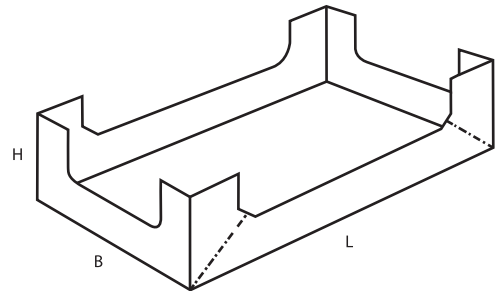
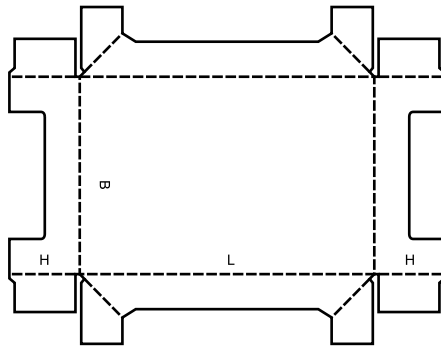

0771 M

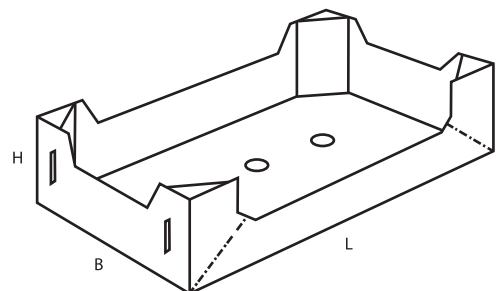
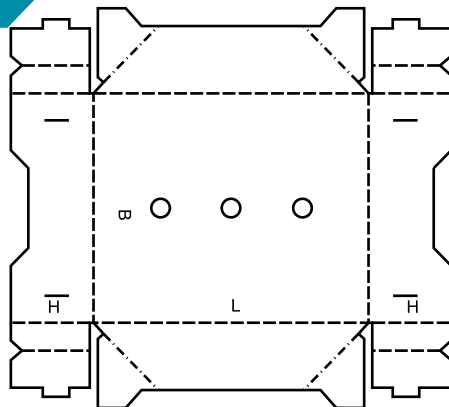

0772 M

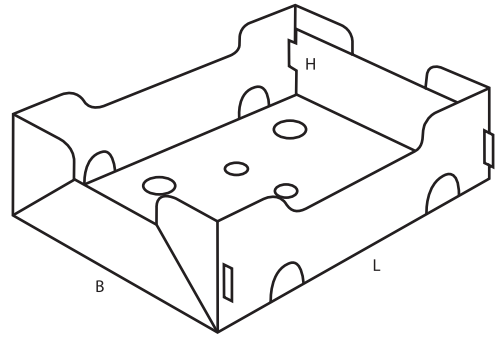
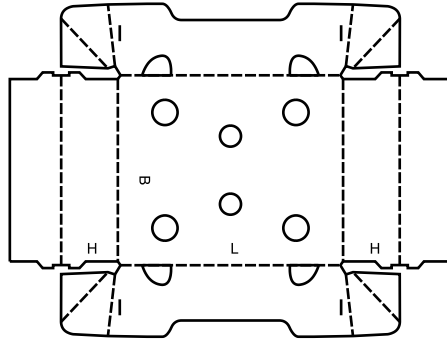

0773 M

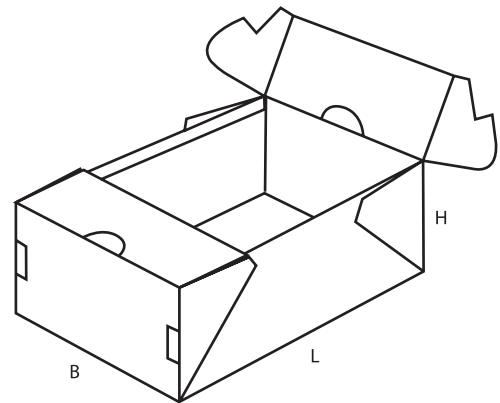
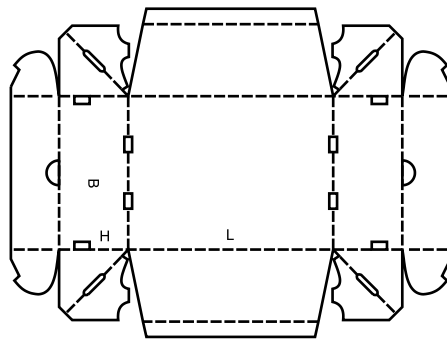

0774 M

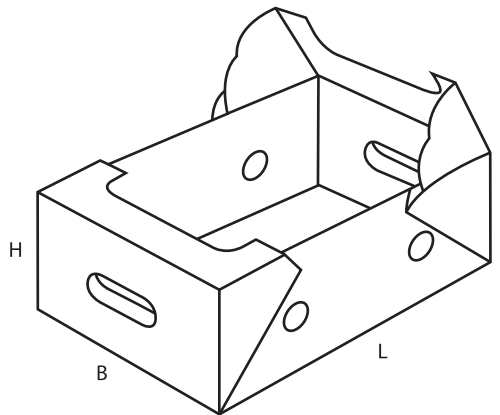
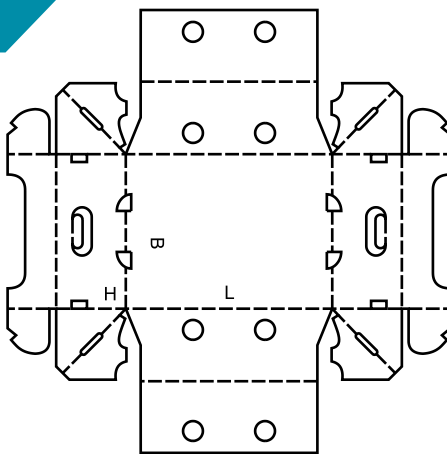

0900

- ▲ **Interior fitments** such as inside liners, pads, partitions, dividers etc., whether tied to Case Design or as singular items. Any shown number of panels is arbitrary and may be increased or decreased as required.
- ▲ **Conditionnement intérieur**, tel que doublures intérieures, rembourrages, casiers, cloisons, etc ... , faisant partie du modèle de caisse ou utilisés comme éléments indépendants. Tout nombre de panneaux indiqué est arbitraire et pourra être augmenté ou diminué selon les besoins.
- ▲ **Inneneinrichtungen** wie Einlagen, Einsätze, Stege, Trennwände, Gefache, Polster und dgl., ob mit der Kiste fest verbunden oder als getrennte Elemente.

Zahlenangaben für Wände sind beliebig und können ggf. höher oder niedriger ausfallen.

- ▲ **Protezioni interne:** Pezzi interni come fodere interne, imbottiture, separatori, divisori ecc., sia come accessori ad un imballaggio, sia come articoli a se stanti. I numeri di pannelli che compaiono nei disegni sono arbitrari e possono essere diminuiti o aumentati secondo le esigenze.
- ▲ **Acondicionadores interiores:** como forros, refuerzos, casilleros, divisiones interiores, tanto si se ajustan a un modelo de caja o como piezas sueltas. El número de piezas de los acondicionadores interiores mostrados es arbitrario y puede aumentarse o disminuirse de acuerdo con las necesidades.

0900 M

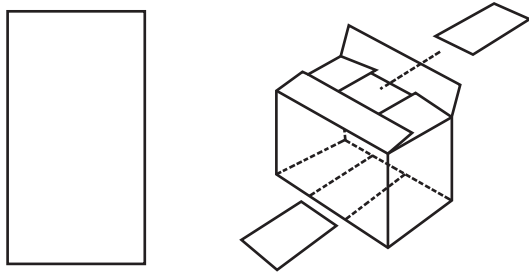

0901 M

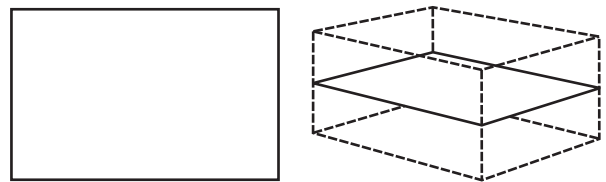

0902 M

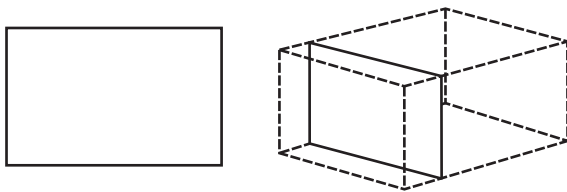

0903 M

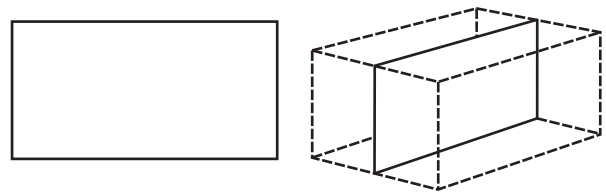

0904 M

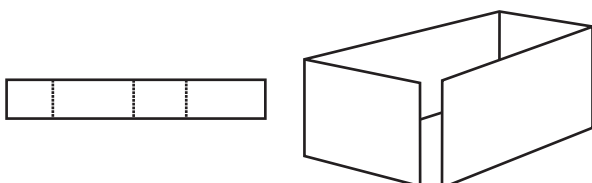

0905 M

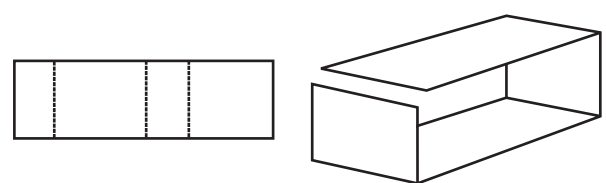

0906 M

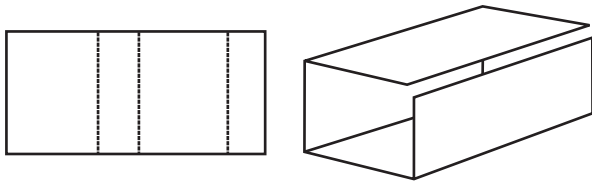

0907 M

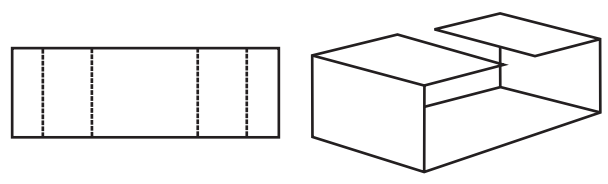

0908 M

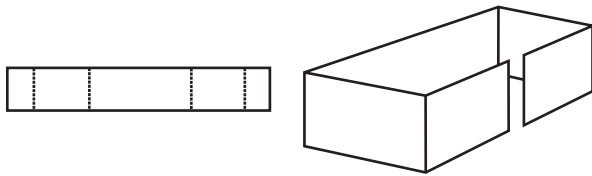

0909 M

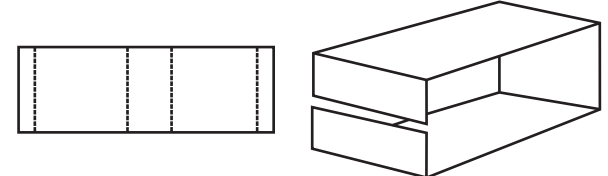

0910 M

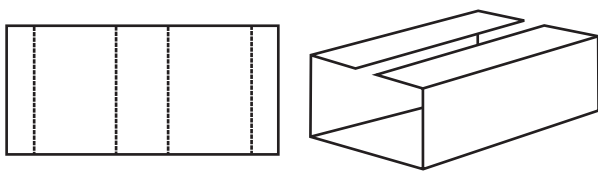

0911 M

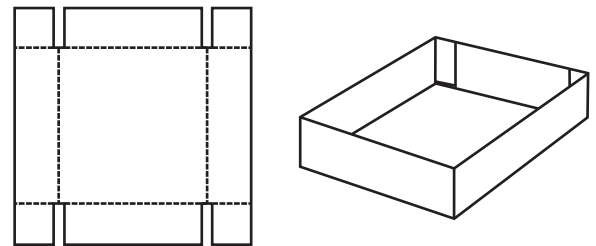

0913 M

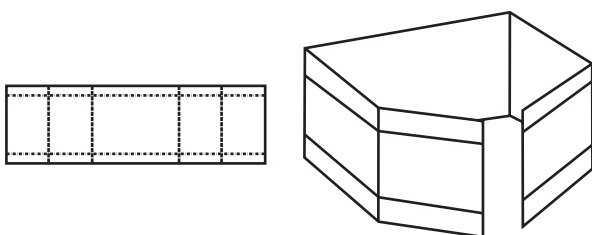

0914 M

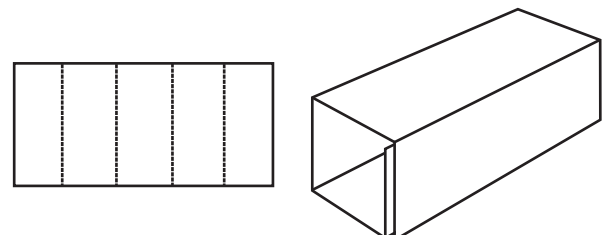

0920 M

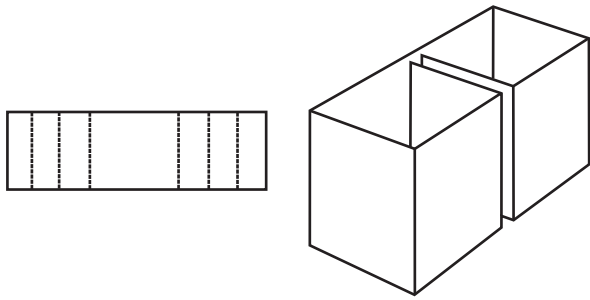

0921 M

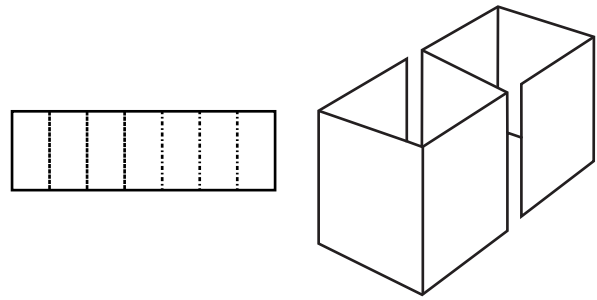

0929 M

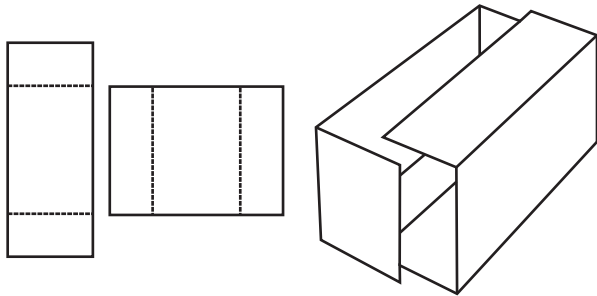

0930 M

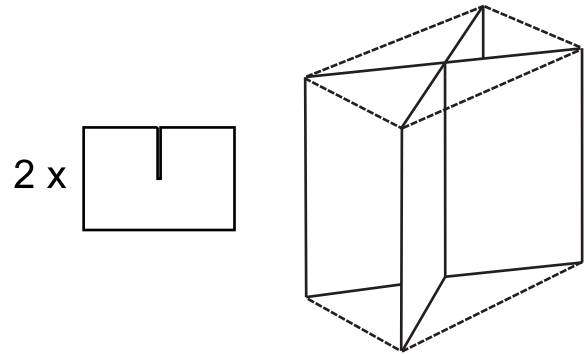

0931 M

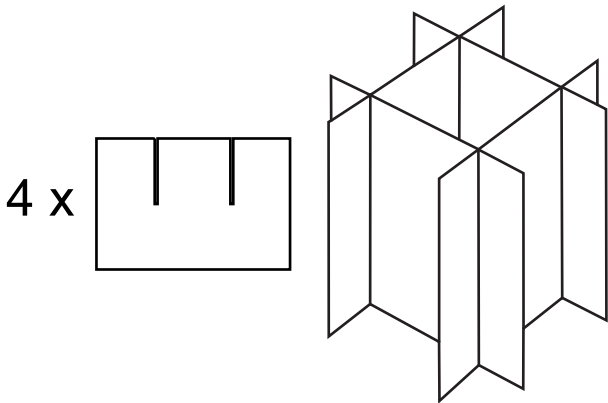

0932 M

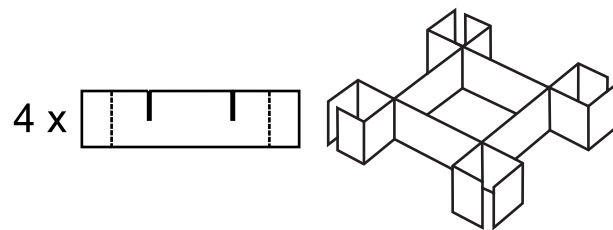

0933 M

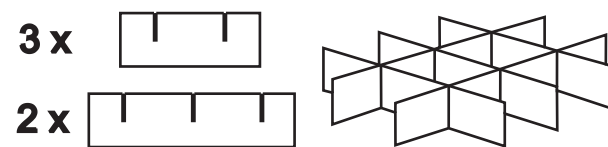

0934 M

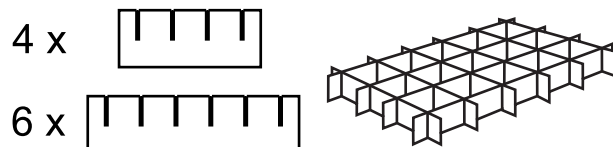

0935 M

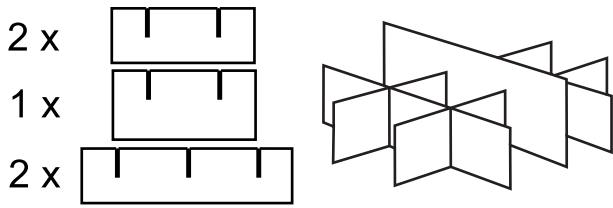

0940 M



0941 M

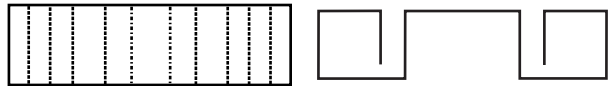

0942 M

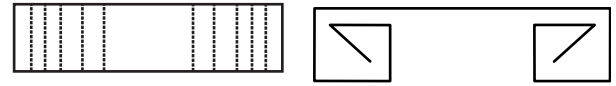

0943 M



0944 M

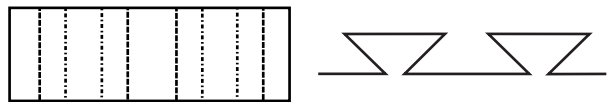

0945 M



0946 M



0947 M



0948 M

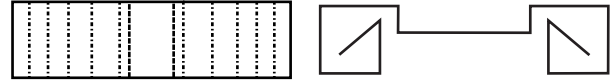

0949 M

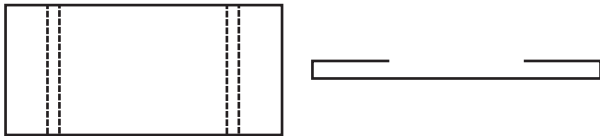

0950 M

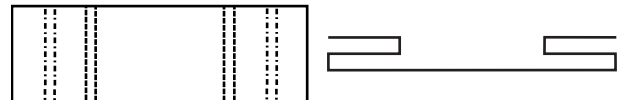

0951 M

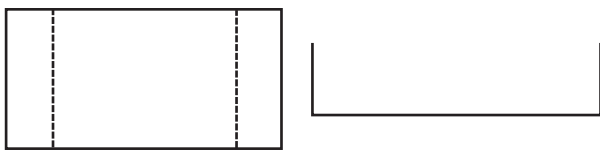

0965 M

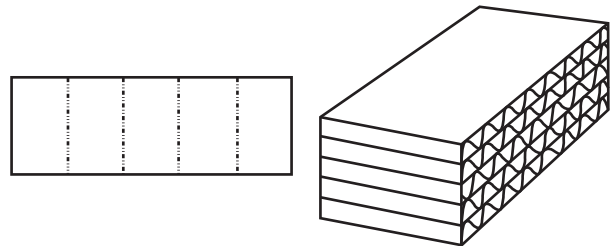

0966 M

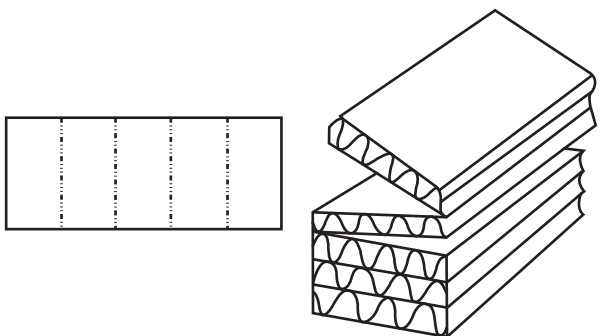

0967 M

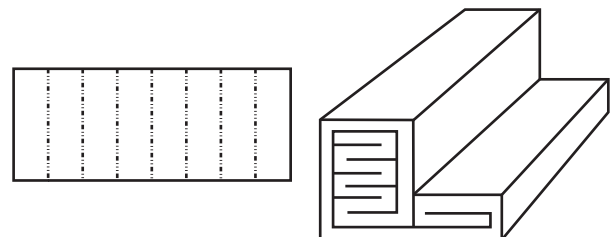

0970 M

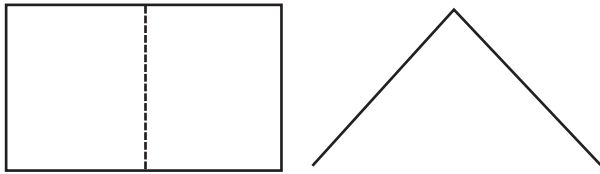

0971 M

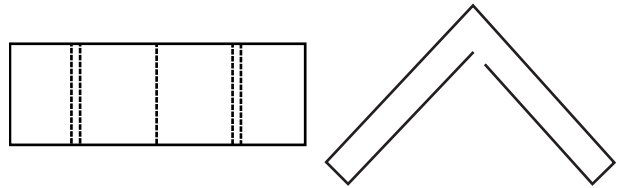

0972 M

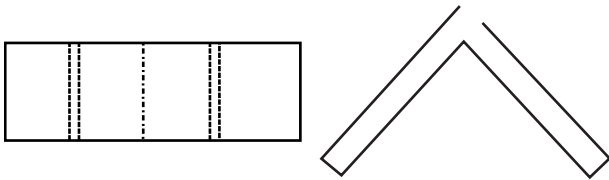

0973 M

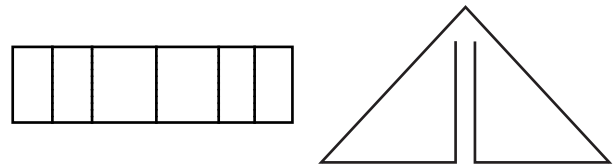

0974 M

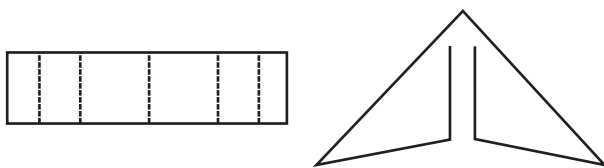

0975 M

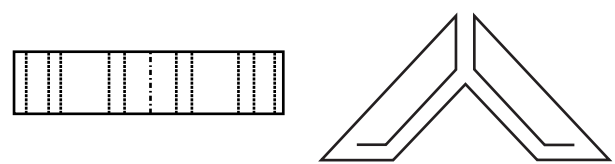

0976 M

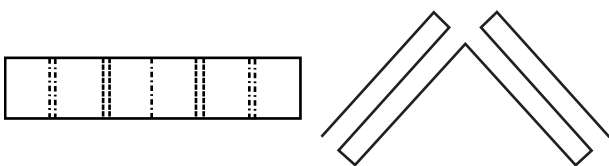

FEFCO

Corrugated Packaging

250 avenue Louise 1050 Brussels
Tel: +32 2 646 4070
Fax: +32 2 646 6460
E-mail: info@fefco.org
Twitter @FEFCO

www.fefco.org

Member of

citpa

ICA